

CD Changer

**Models: CDP-CX235
CDP-CX270
CDP-CX335
CDP-CX400
CDP-CX450**



Circuit Description and Troubleshooting

Course: A-122

Sony Service Company
A Division of Sony Electronics Inc ©2000
All Rights Reserved
Printed in U.S.A.

SONY is a trademark of Sony Electronics

Circuit Description and Troubleshooting:

Models: CDP-CX235
CDP-CX270
CDP-CX335
CDP-CX400
CDP-CX450

Prepared by: National Training Department
Sony Service Company
A Division of Sony Electronics Inc.

Course presented by _____

Date _____

Student Name _____

Table of Contents

Overall Block Diagram	3	Tray Table Motor Drive	21
Information Gathering	3	CD Location & Label Storage	23
CD Playback	3	Disc Loading Drive	27
Power Supply / Display	5	Operation	27
Power Supply	5	Motor Stop	27
Fluorescent Display	7	Optical Pickup	29
Power On	11	The Laser and Lens	29
AC Power Only	11	Focus Coil	29
Power ON	11	Tracking Coil	29
Communications IC501 - IC701	11	Detector Outputs	29
Communications IC501 - IC101	13	Servo / Audio Processing Block	31
Door Motor Drive	15	Servo Block	31
Operation	15	Sled Motor	31
Drive	15	Focus Servo	31
Feedback	15	Tracking Servo	33
Tray Table Positioning	17	Spindle Motor	33
Tray Table Slots	17	Audio Block	33
Light Sensors	17	Servo Processing	35
Table Motor Drive	19	Sled Motor Drive	35
Front Panel Rotary Encoder - Operation	19	Laser	35
Direction of Rotation	19	Focus	35
Tray Table Position Sensors	19	Tracking Servo	35

Spindle Servo	37
Audio / Display Output	39
Analog Audio Output	39
Digital Output	39
Display	39
Troubleshooting	41
Disc Doesn't Spin	42
Servo Processing Diagram	43
Focus	44
Disc Won't Spin Flowchart	45
Disc Spins, But Doesn't Read the Disc's Table of Contents (TOC)	47
RF Output	47
Tracking Servo	47
Disc Spins, But Does Not Read TOC Flowchart	48
Spindle Servo	49
No Audio	50
Optical Assembly Tests	51
S Curve Check	51
E-F Balance Check	51
RFO Level Check	52

APPENDIX

Control A Communications for Additional Features	i
Defective Discs	iii
Troubleshooting Using the RFO Waveform	v
Abbreviations Used in Compact Disc Player	vi

CD Mega Changer Product Line (USA)											
Model	Disc Capacity	List Price	Cd Mech	BD Board	List Price	Optical Assembly / Part number	List Price				
All of these numbers sub to 8-848-379-31											
2000											
CDP-CX235	200	\$170.00	CDM-40B	A4724029A	\$76.15	KSS-213BNK / 8-848-379-31	\$ 82.12				
CDP-CX270	200	\$1,000	CDM-40B	A4699163A	\$112.01	KSS-213B / 8-848-376-01	\$ 82.12				
CDP-CX335	300	\$300.00	CDM-54-KIBD35E	A4724761A	\$82.12	KSS-213BFN / 8-848-379-31	\$ 82.12				
CDP-CX400	400	\$360.00	CDM-62-K1BD35A	A4724761A	\$82.12	KSM-213BFN / 8-820-026-03 *	\$ 82.12				
CDP-CX450	400	\$480.00	CDM-62-K1BD35A	A4724761A		KSM-213BFN / 8-820-026-03 *	\$ 82.12				
*use 'CX335 manual for part number											
1999											
CDP-CX225	200	\$250.00	CDM-40	A4699038A	\$112.01	KSS-213B / 8-848-376-01	\$ 82.12				
CDP-CX230	200	\$300.00	CDM-40B	A4724029A	\$76.16	KSS-213BNK / 8-848-379-31	\$ 82.12				
CDP-CX270	200	\$1,000	CDM-40	A4699038A	\$112.01	KSS-213B / 8-848-376-01	\$ 82.12				
CDP-CX300	300	\$360.00	CDM-54-KIBD35E	A4724761A	\$82.12	KSS-213BFN / 8-848-379-31	\$ 82.12				
CDP-CX350	300	\$480.00	CDM-54-KIBD35E	A4724761A		KSS-213BFN / 8-848-379-31	\$ 82.12				
CDP-CX691	300		CDM-54-KIBD35E	A4724761A		KSS-213BFN / 8-848-379-31	\$ 82.12				
1998											
CDP-CX210	200		CDM-40	A4699038A	\$112.01	KSS-213B / 8-848-376-01	\$ 82.12				
CDP-CX220	200		CDM-40B	A4724029A	\$76.16	KSS-213BNK / 8-848-379-31	\$ 82.12				
CDP-CX240	200		CDM-40B	A4724029A		KSS-213BNK / 8-848-379-31	\$ 82.12				
CDP-CX260	200		CDM-40B	A4724029A		KSS-213BNK / 8-848-379-31	\$ 82.12				
CDP-CX270	200		CDM-40	A4699038A	\$112.01	KSS-213B / 8-848-376-01	\$ 82.12				
CDP-CX90ES	200	\$1,100	CDM-40	A4699038A		KSS-213B / 8-848-376-01	\$ 82.12				

List Prices are as of 7/1/00

Introduction

This training manual is based upon the model CDP-CX235 CD Changer. This model is the entry changer in the “Mega” Changer product line for the year 2000. The “2” in the model number refers to the 200 disc capacity of these Changers. These 200 series models are mechanically complex so there are more CD transport and mechanical adjustments to be made.

The concepts and circuitry in this 200 disc model are similar to the 300 disc CDP-CX300 series and 400 disc CDP-CX400 series CD Changers. In these larger capacity models, the CD transport and CD mechanism use fewer parts. As a result, the higher capacity Changers require fewer adjustments.

Generally, the electrical troubleshooting procedures and test modes outlined in this training manual can be applied to all of the changer models listed for the last three years. This is because for troubleshooting purposes, they are electrically similar. Mechanically, the 200 disc Changers use one basic chassis and the 300 and 400 disc Changers use another chassis so the mechanical adjustments differ.

Model CDP-CX90ES/CDPCX-270

The model CDP-CX90ES/CDPCX-270 was carried over from the 1998 year because it was the only chassis that had the following major features:

- A video output for an on-screen display using a TV.
- A front panel jack that permitted a computer keyboard to be plugged in. This allowed the user to label or re-label each CD slot location quickly using the keyboard instead of the slower remote control.

Model CDP-CX235

The board layout of the CDP-CX235 is shown. The bulk of the electronics are on the rear main board. To its left in the vacant area is the CD mechanism housing the optical assembly and servo (BD) board. The small boards along the bottom of the chassis hold the tray table and disc sensors. The top illumination board houses 3 LEDs to light the disc compartment when the CD Changer is powered on.

Overall Block Diagram

At the core of the 200 disc CD Changer is the System Control (Syscon) IC501. IC501 serves as the interface between the user and the mechanism. Before IC501 can respond to the user's commands for a disc to play, it must know the following:

- If the Disc door is closed.
- If the CD Mechanism is in the chucked position.
- At which disc slot the tray table is positioned.

Some of this information is stored in an external memory IC; the remainder IC501 will have to gather at power ON using the sensors and switches linked to the Door, Tray Table and Loading Motors.

Information Gathering

Pressing the power ON button causes IC501 to use "IC SW" to switch on regulator IC506. IC506 applies power to the BD board, which houses the optical assembly. D+5V is also applied to the LED in the door compartment to inform the user power is ON.

After Syscon IC501 turns on power, IC501 accesses its external memory IC. Data about the disc last loaded in the CD Mechanism is returned to IC501. The disc label information is output as data to the FL Display IC for display on the front panel fluorescent tube. If there was no label information, then just the disc's number is displayed.

Syscon now takes a series of steps to check the memory information:

1. Syscon activates the disc door motor to close the door if its corresponding switch indicates the door is open.
2. Next, Syscon checks the loading motor switch position to see if the CD Mechanism is in the chucked position (disc loaded).
 - If chucked, IC501 will initiate disc PB to read its TOC.
 - If unchucked, IC501 will drive the tray table motor, rotating its discs past the disc sensors. While the tray is rotating, the tray sensors inform IC501 of the disc slot location while the disc sensor tells IC501 if there is a disc present at that slot. The last disc played according to memory will be loaded and its TOC read (if present).

Once Syscon IC501 is confident the tray table information is valid, IC501 turns the CD Changer control over to the user by accepting pushbutton commands.

The user can use the front panel controls to select another disc or play that one. When Syscon knows the loading motor is in the chucked position (loading motor switch), the CD can be played.

CD Playback

Syscon IC501 initiates CD play by sending data, clock and latch communications to IC101 on the BD board. This causes IC101 to turn on the laser, focus, tracking and spindle servos that employ the laser diode, along with the focus coil, tracking coil, sled motor and spindle motor in the optical assembly.

Once these servos are operating, the disc information (RFO) is output. RFO is received by Servo Control IC101 which:

- Converts the data back to the original modulation scheme (EFM).
- Error corrects the data (parity error correction).
- Reconstructs its original pattern (CIRC).
- Creates additional digital samples (oversampling) to reduce noise in the final analog audio.
- Converts the signal from digital to analog form (D/A Converter).

Analog audio is output from IC101 to the rear panel jacks.

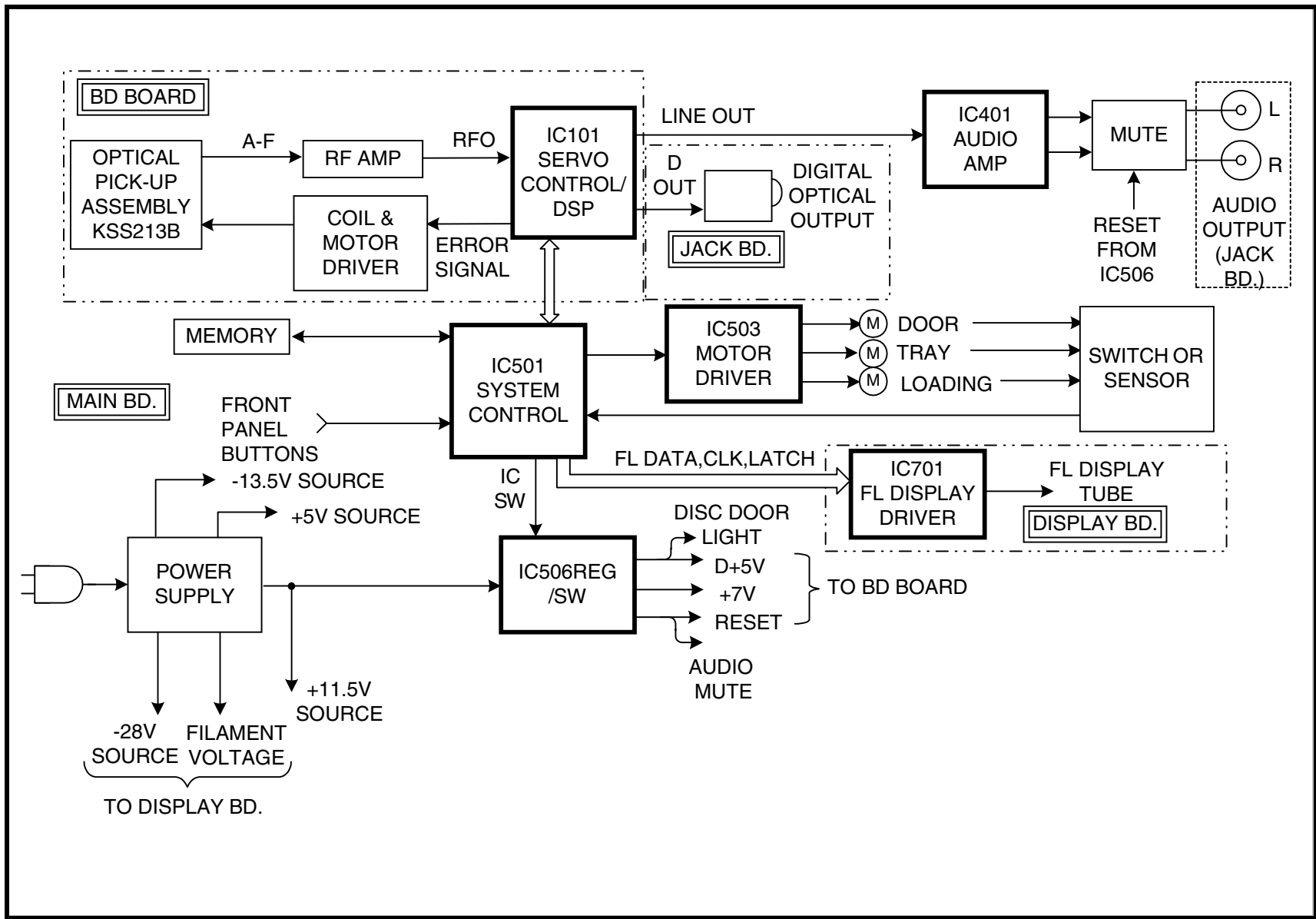

OVERALL BLOCK DIAGRAM (MODEL CDP-CX235)

0A122 1251 7/5/00

Power Supply / Display

Overview

The power supply stage produces seven voltages when the CD Changer is plugged into AC. Some of these voltages from the main board power the FL Driver microprocessor IC701 and the FL indicator tube on the display board.

Power Supply

Power Supply Output		
Output Voltage	From	Destination
1. +11.5Vdc	Bridge Rectifier D501-4	Regulator/Sw IC506, +5V Regulator IC504, Motor Driver IC503.
2. 13.5Vdc	Bridge Rectifier D501-4	Audio mute transistors (Q325/e, Q327/e and Q425/e), Motor driver IC503.
3. +5Vdc Source	Regulator IC504	Syscon IC501 (not shown), FL Driver IC701.
4. +5Vdc	Bridge D501-4 & Zener D508	Mute transistors Q325/e, Q327/e and Q425/e.
5. Reset +5V	Reset IC505	Syscon IC501 (not shown), FL Driver IC701, LED Driver IC702 (not shown).
6. 3.7Vac	Power Transformer T901	Fluorescent Display Tube filament
7. -28V	Q501/emitter	Reference voltage for the Fluorescent Display

+11.5V Source / -13.5V Source

When the CD Changer is plugged into AC, this voltage is applied to the primary winding of T901. The secondary winding that is center taped applies 20.6Vac to a four-diode bridge rectifier designated D501 to D504.

The positive output of the bridge rectifier is filtered by C501 to become the +11.5V source voltage.

The negative output of the bridge rectifier is filtered by C502 to become the -13.5V source voltage.

+5Volt Source

The +11.5V source voltage is reduced and regulated by IC504 to produce the +5V source voltage for the CD Changer.

+5Vdc

The +11.5V source voltage is reduced by R505 and R508 and applied to 5.1 volt zener diode D508 for shunt regulation. Shunt regulation is when a device like this variable resistance zener diode is placed in parallel with the load. The zener diode resistance varies to keep the voltage at the load reasonably stable.

This +5 volts that is output is used by the mute transistors Q325, Q327, and Q425 to control the left and right channel audio muting at power ON and OFF and when plugged and unplugged from AC.

D509 and C505 are used to insure there is sufficient voltage for the mute operation when the unit is unplugged. C505 holds the +5V for the mute transistors and diode D509 blocks this voltage from being used by the loads on the 11.5V line (D509/anode).

Reset +5V

When the +5Volt Source voltage outputs regulator IC504, IC505 creates a reset pulse using R506 and C507. Each one of these three parts has a role in creating the reset pulse. When the source voltage is input IC505, IC505 holds it output LOW for a fixed amount of time dependent upon IC505's design. This LOW grounds out C507 at the output. When the IC505 releases ground, C507 is charged by R506 to +5V.

The reset output of IC505 is applied to the IC501 and IC701 microprocessors in this CD Changer. Generally, reset occurs when the reset input to a device is held LOW while power (Vcc) is applied.

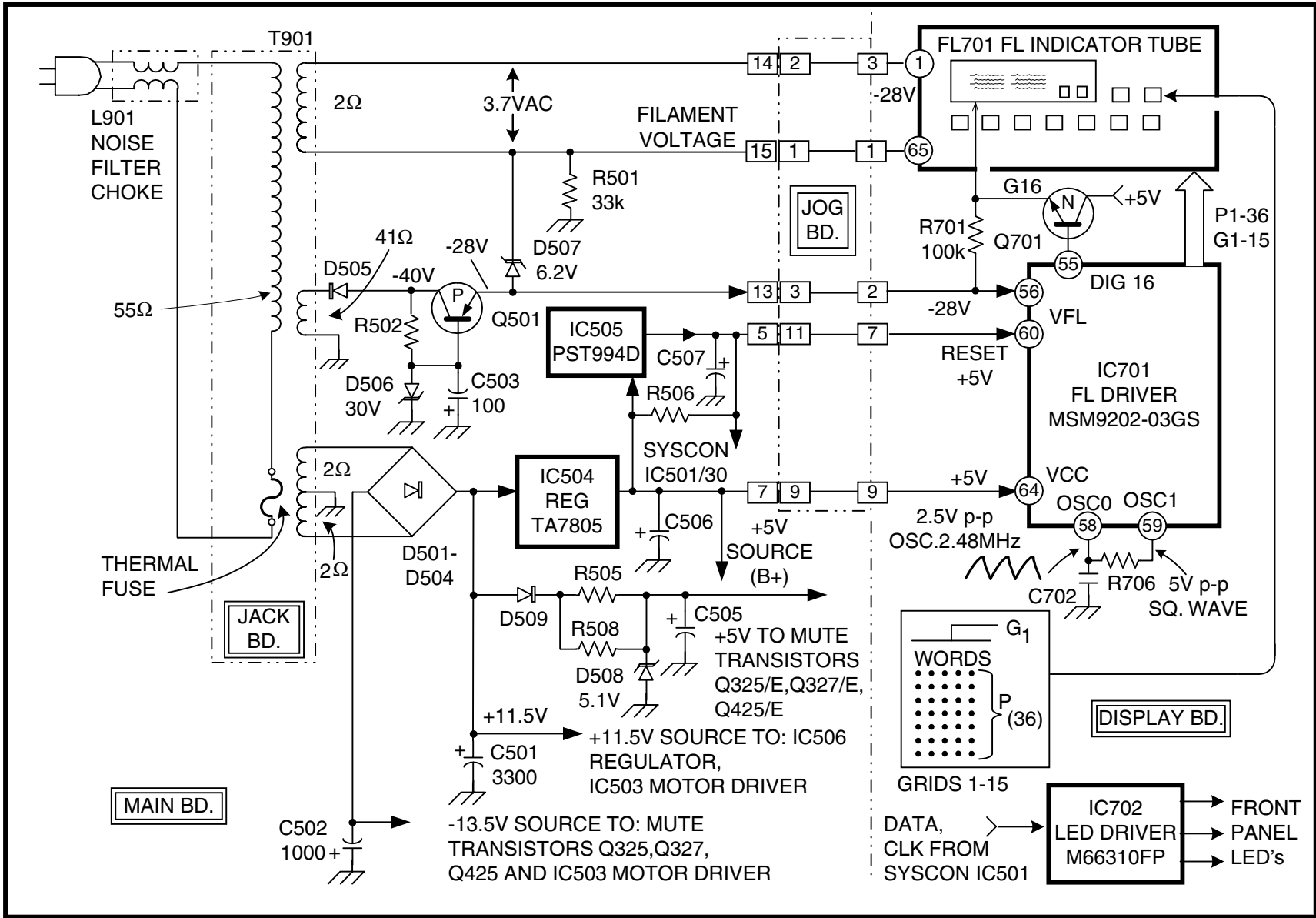

POWER SUPPLY (CDP-CX235)

1A122 1238 7/7/00

When the output of IC505 is LOW, these microprocessors are held in reset and are inactive (apparently dead).

3.7Vac

A low AC voltage from power transformer T901 is applied to the filament of the fluorescent indicator tube FL701.

-28V

The 41-ohm secondary winding of transformer T901 produces 31.7Vac that is rectified by D505. The -40Vdc produced is regulated by Q501 using zener diode D506 for voltage stabilization.

The -28Vdc output from regulator Q501/emitter is applied to the fluorescent driver stage as the negative supply voltage and to one end of the filament via D507 as the tube's electron source.

Fluorescent Display

The FL701 Fluorescent Display tube needs the following to light a segment or a word in the tube:

- Filament voltage
- Positive voltage simultaneously applied to the grid and plate.

Basic Operation

The filament voltage comes from the power transformer T901 and the positive pulses come from FL Driver IC701.

Just like a vacuum tube, the fluorescent display tube needs a source of electrons. The electrons come from the filament, which is connected to the -28V source. A controlling grid in the middle acts as a gate to determine if electrons should pass onto the plate to make it glow. At the gate, a more positive voltage than the filament attracts the electrons and opens the gate. A grid voltage that is the same as the filament will keep electrons from leaving the filament so there is no glow.

The plate structures will be phosphorescent when struck by electrons. To get the electrons to the plate, the plate must have a positive voltage to be attractive.

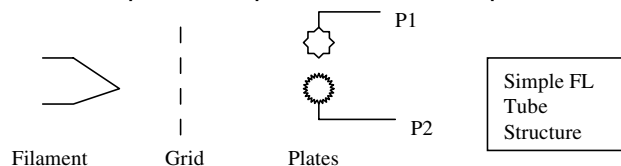

Grid & Plate Array

Within the FL tube there are 16 grid structures, each containing 36 plates. Each grid structure produces a character or number by luminating a combination of plates.

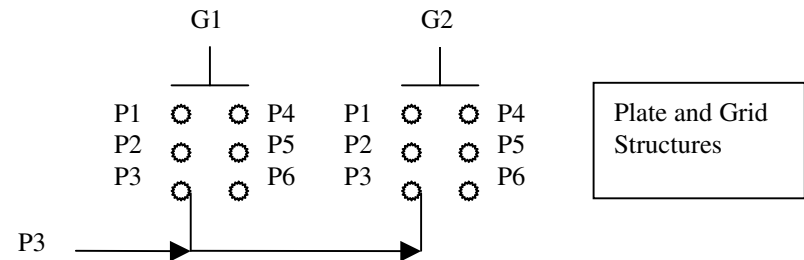

To make a specific plate glow, a grid structure is selected and a positive voltage is applied to it. At that time, the plate structures that must glow are also brought positive. In the diagram above, when G1 and P3 lines are brought HIGH, the P3 plate in the G1 structure will glow. Even though the P3 structure in the G2 structure is connected in parallel, receiving the same voltage, it will not glow because the G2 voltage is LOW at this time. The job of FL Driver IC701 is to create and time the grid and plate pulses.

Fluorescent Driver IC701

When the CD Changer is plugged into AC, Vcc is applied to IC701/pin 64, starting its internal oscillator. The R-C parts that set the frequency of this 2.48MHz oscillator (16MHz is on the schematic) are located at IC701/pins 58 and 59.

Also at AC plug in, the FL Driver IC701 is momentarily reset. IC505 momentarily holds its output LOW when +5V is input. This LOW resets FL Driver IC701 when Vcc (power) is present at pin 64. The LOW lasts for $0.2\text{ms (IC505)} + 0.8\text{ms (C507)} = 10\text{ms}$.

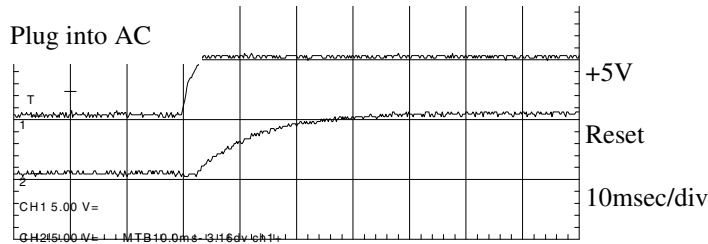

After reset, IC701 begins normal operation, producing sequential grid pulses first. When IC701/pin 60 goes HIGH (+5V), IC701 outputs a positive going pulse at each grid pin, one after the other. Each grid pulse is applied to a grid cluster consisting of 36 individual plate structures. After all 16 grids are pulsed (G1 – G16), the sequence repeats. Nothing appears in the display at plug-in because the fluorescent tube has not received plate voltage.

The waveform below shows grid pulses applied to G14, G15, and G16 of the fluorescent tube.

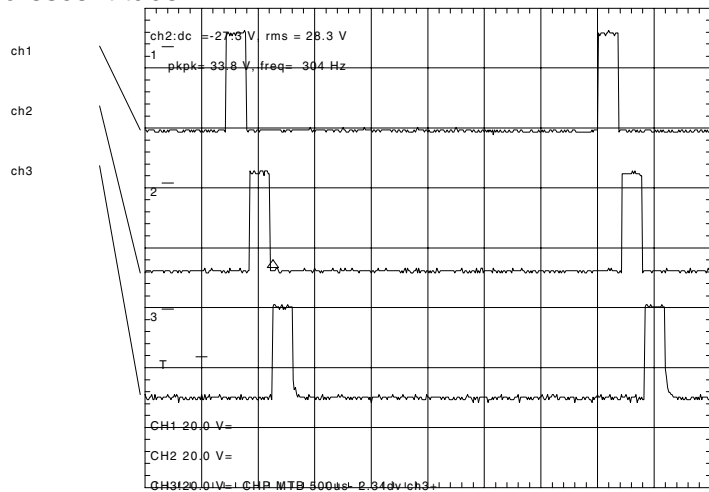

Fluorescent tube Grid pulses at Power OFF			
Chan	Name	Location	Voltage
1	G14	IC701/pin 53	30Vp-p
2	G15	IC701/pin 54	30Vp-p
3	G16	IC701/pin 55	30Vp-p
Time base = 500usec			

Plate voltage pulses appear only when the CD Changer is powered ON. At power ON, Syscon (IC501 is not shown) sends data to IC701 so it can output these pulses. Positive pulses are output the appropriate plate pins P1-36 to form a number, letter or word when a grid pulse is simultaneously present.

The following waveforms show a plate signal (Ch 1) compared to the grid 16 signal (Ch 3). This plate segment is lit at the grid assembly 16 location when both the plate and the grid outputs are HIGH.

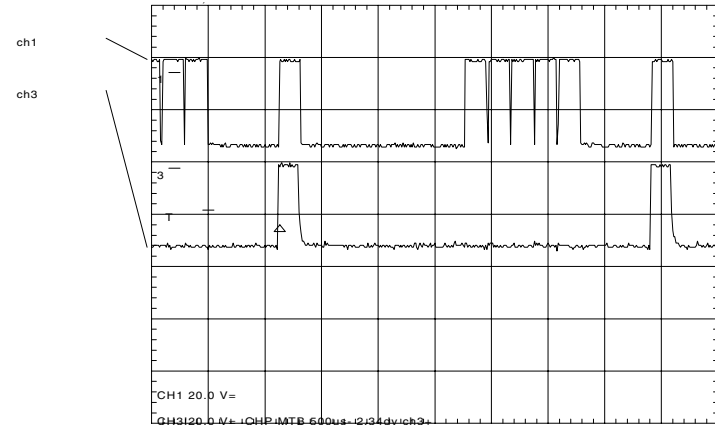

Fluorescent tube pulses during Power ON			
Chan	Name	Location	Voltage
1	P14	IC701/pin 18	30Vp-p
3	G16	IC701/pin 55	30Vp-p
Time base = 500usec			

By looking at Channel 1, we see that the plate signal also goes high at times when grid 16 is not HIGH (Ch 3 = LOW). This means a similar plate at a different grid is lit at this time.

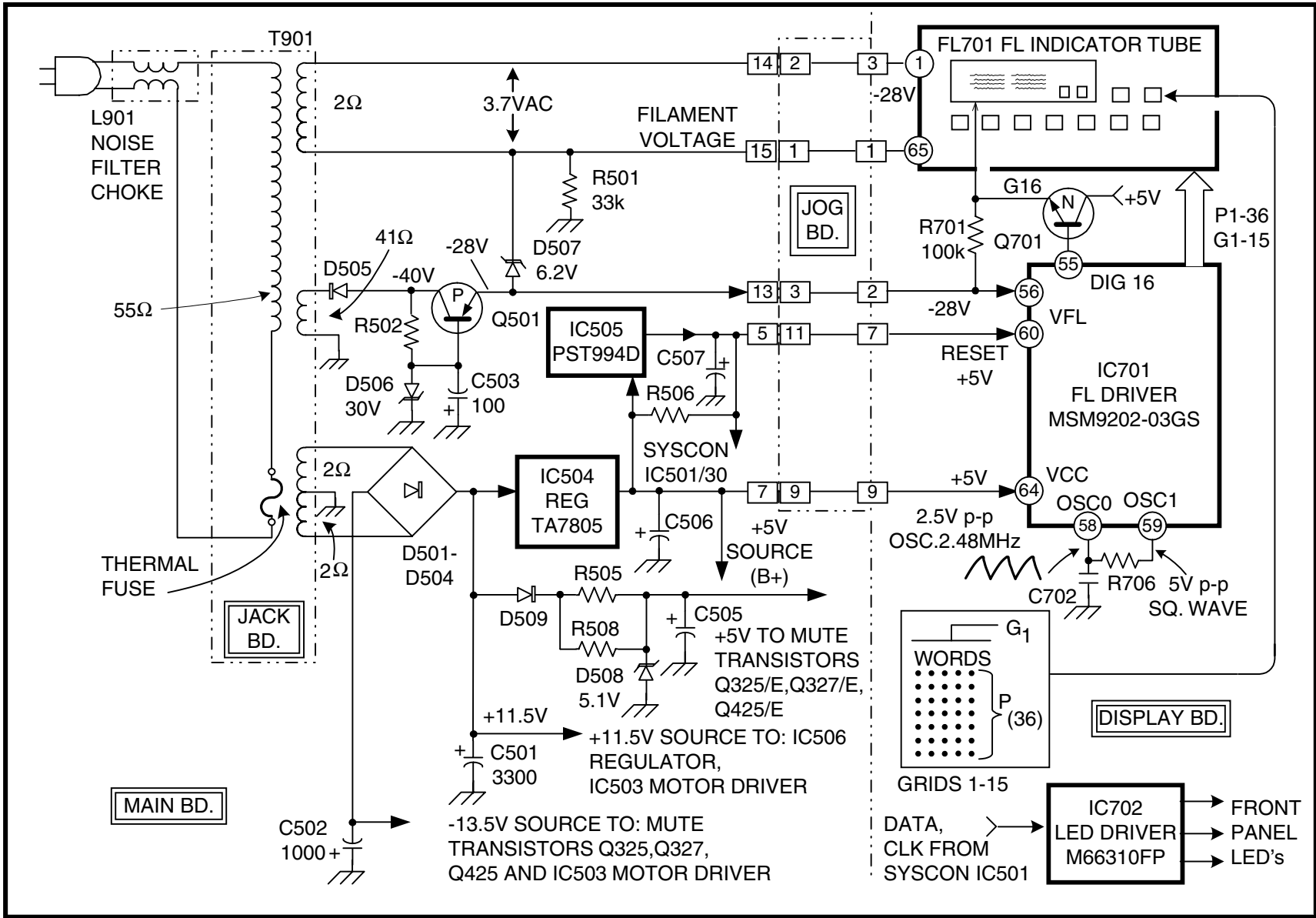

POWER SUPPLY (CDP-CX235)

1A122 1238 7/7/00

Power On

Once the CD Changer is plugged into AC, pressing the front panel Power button permits Syscon to enable regulator IC506. IC506 outputs D+5V, +7V, and a reset signal to power the remaining devices on the BD board and turn on 2 LEDs to illuminate the disc door compartment.

AC Power Only

When the CD changer was plugged into AC, Syscon IC501 received power at pin 37 and was fully functional as marked by the X501 activity at pins 31 and 32. There is even data and clock signals leaving IC501/pins 18, 19 and 58. These signals go to FL Display Driver IC701, but there is no instruction to turn on the front panel display while the unit is still OFF.

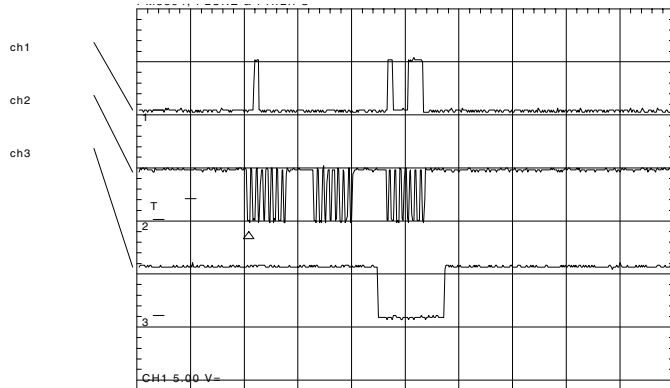

IC501 Activity at Power OFF		
Channel	Name	CN501/pin
1.	FL Data	1
2.	FL CLK (Clock)	2
3.	FL LT (Latch)	4
Time base = 50usec/div		

Power ON

Syscon IC501 receives the power ON command from the front panel push button at pin 44 (LOW). IC501 responds by outputting a HIGH at IC SW

pin 65 to enable regulator IC506. IC506 has three outputs:

1. D+5V from pin 2 is used to:
 - Power the digital ICs on the DB board; and
 - Turn on the LED at the disc door compartment. This also lets the user know the unit is ON.
2. +7V from pin 9 is used to:
 - Power the focus/sled/tracking driver IC102; and
 - Power the coils and motors on the BD board
3. XRST from pin 6 goes HIGH to:
 - Unmute the analog audio output lines; and
 - Enable Servo Control IC101 and the focus/sled/tracking driver IC102 on the BD board.

Communications IC501 – IC701

At power On, the communications activity increases between IC501 and IC701. This is to provide constant update information to the display IC701.

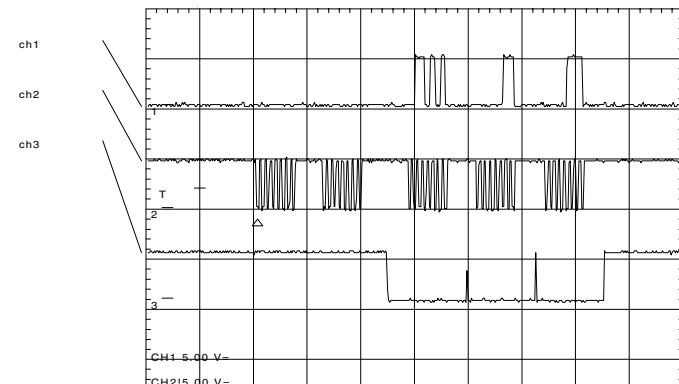

IC501 Activity at Power ON		
Channel	Name	CN501/pin
1.	FL Data	1
2.	FL CLK (Clock)	2
3.	FL LT (Latch)	4
Time base = 50usec/div		

Communications IC501 – IC101

Communications from Syscon to Servo Control IC101 does not occur until the disc is chucked on the spindle motor and ready to play (after the loading motor finishes chucking the disc). This communications is shown below:

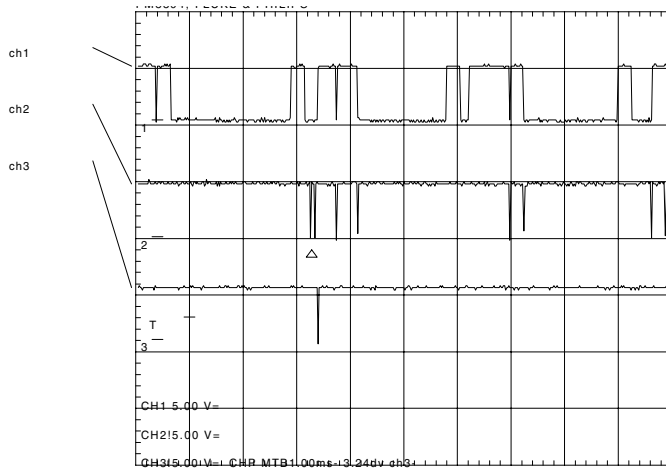

IC501 Activity at CD Play		
Channel	Name	CN502/pin
1.	Data	18
2.	CLK (Clock)	20
3.	XLT (Latch)	19
Time base = 1msec/div		

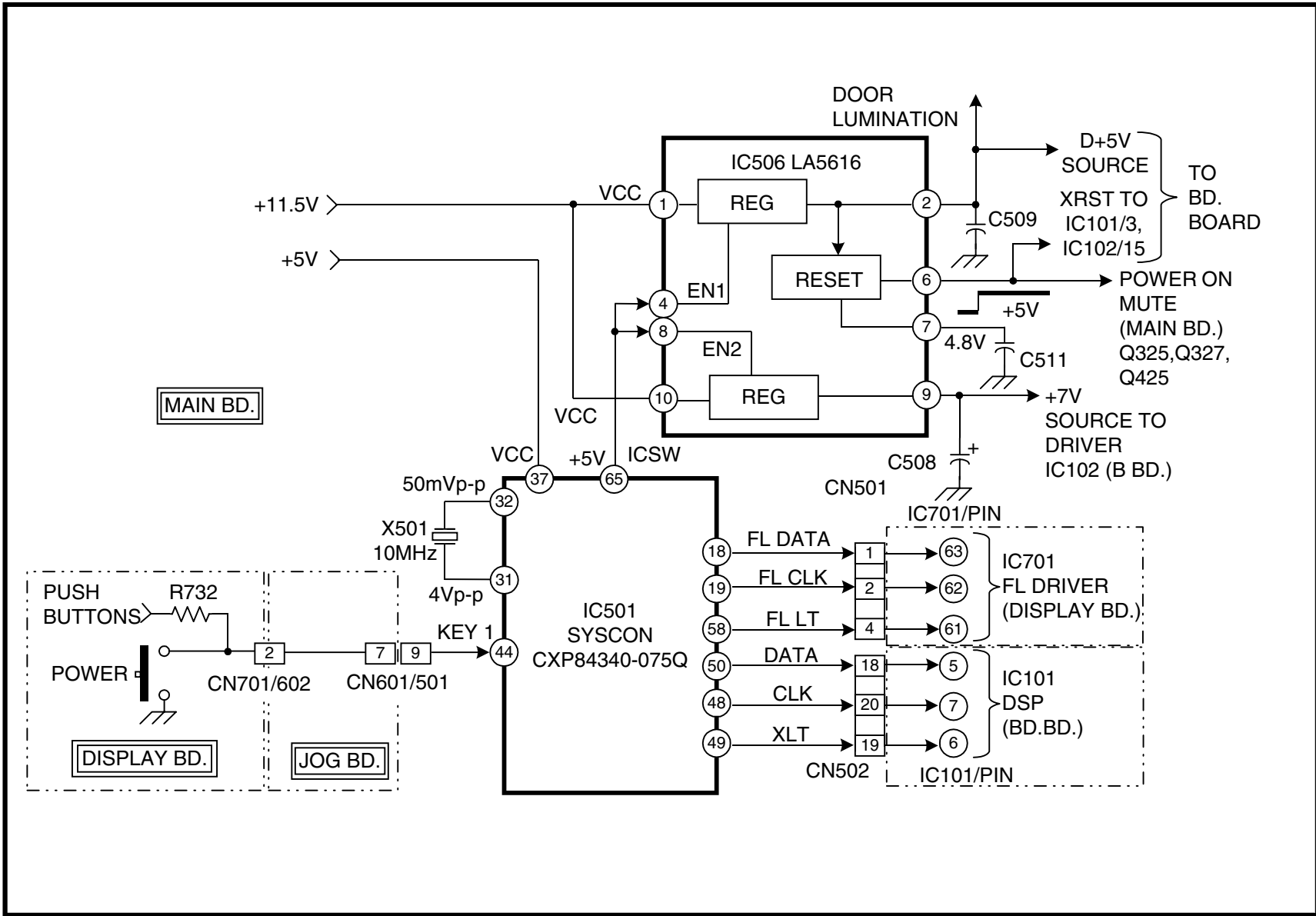

POWER ON

2A122 1242 6 28 2000

Door Motor Drive

The sliding door in the model CDP-CX235 was an improved feature over the previous manual trap door that the user pulled down to access the disc tray table. The sliding door mechanism consists of a motor that drives a series of gears to slide the door on plastic tracks. The door motor stops turning when the limit switch is toggled in the closed or open position.

Operation

Syscon IC501 controls the door movement. Only after the CD Changer is powered ON will IC501 respond to the OPEN/CLOSE Door button at the Key 2 input (IC501/pin 43).

Pressing the door button causes IC501 to check the position of the door. S810, a 3-position switch, places one of three voltages at Syscon IC501/pin 39 to indicate the door position.

Door Position Feedback		
Door Position	Location	Voltage
Closed	CN504/pin 1	2.5V
Neutral (in-between)	CN504/pin 1	5V
Open	CN504/pin 1	0V

A closed door will be driven open and vice versa.

Drive

Syscon IC501 applies an output voltage to pin 23 or pin 24 to drive the motor. The resultant positive or negative voltage is applied to the door motor.

Door Motor Drive			
Movement	IC501/pin 24	IC501/pin 23	IC503/pin 9
Door Opening	4.7V	0V	-3.6V
Door Closing	0V	4.8V	+3.7V

Feedback

As the door moves, S810 enters the neutral position and 5V is applied to IC501/pin 39. When the door reaches the end of travel the door toggles the S810 limit switch to the other end. IC501/pin 39 is lowered to either 2.5 or 0V. IC501 responds by stopping the motor voltage at pin 23 or 24

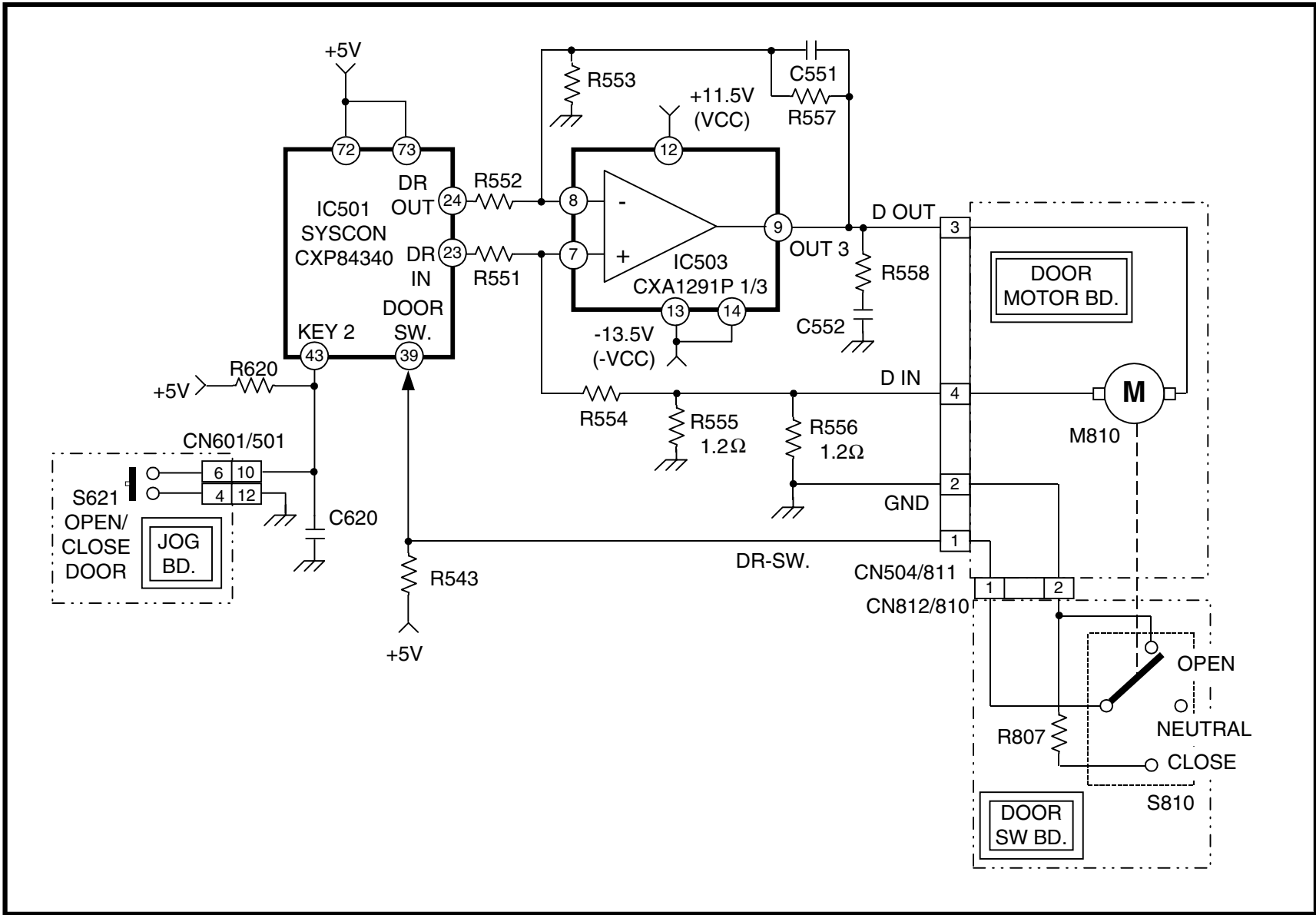

DOOR MOTOR DRIVE

3A122 1243 6 28 2000

Tray Table Positioning

In order for the tray table to be positioned, two rows of slots are molded into the bottom of the rotating tray table forming rings. These slots mate with light sensors stationed on the bottom of the CD Changer. The sensors feed back information to Syscon so it can determine the exact tray table position.

Tray Table Slots

At the bottom of the tray table, outer ring (#2) contains 200 equally spaced slots that look like teeth. Each slot consists of an empty area (gap) in the plastic ring that passes light and an equal width tooth that blocks the light. One ring #2 slot corresponds to one disc slot.

Inner ring (#1) contains different spaced gaps. Ring 1's smallest gap is equal in width to one slot and one tooth pair in ring 2. Ring 1's largest gap is the width of ten of ring 2's slots and teeth (10 disc slots). Generally, the width of a gap is one for each group of 10 disc slots.

Light Sensors

Each light interrupt sensor forms a U channel. At one side of the sensor there is an infrared LED that shines light through the channel. At the other end is a phototransistor that monitors this light. When light passes through the channel (light is received by the phototransistor), the electrical output is HIGH. When the channel is blocked, there is no electrical output.

All three sensors are used to locate the tray position as the tray rotates. Sensor IC801 monitors the gaps in ring #1. Sensors IC802 and IC803 are both used to monitor the gaps in ring #2. IC802 and IC803 sensors are positioned off center to determine the center of the slot. This off center information is necessary so the tray can stop the CD exactly in front of the CD Mechanism each time.

IC801's sensor records Ring #1's gap width. These gaps increase as the number of disc slots increase. Therefore with a minimum rotation of the tray table, the home position can be calculated using the data from IC801 and one of the slot sensors like IC802.

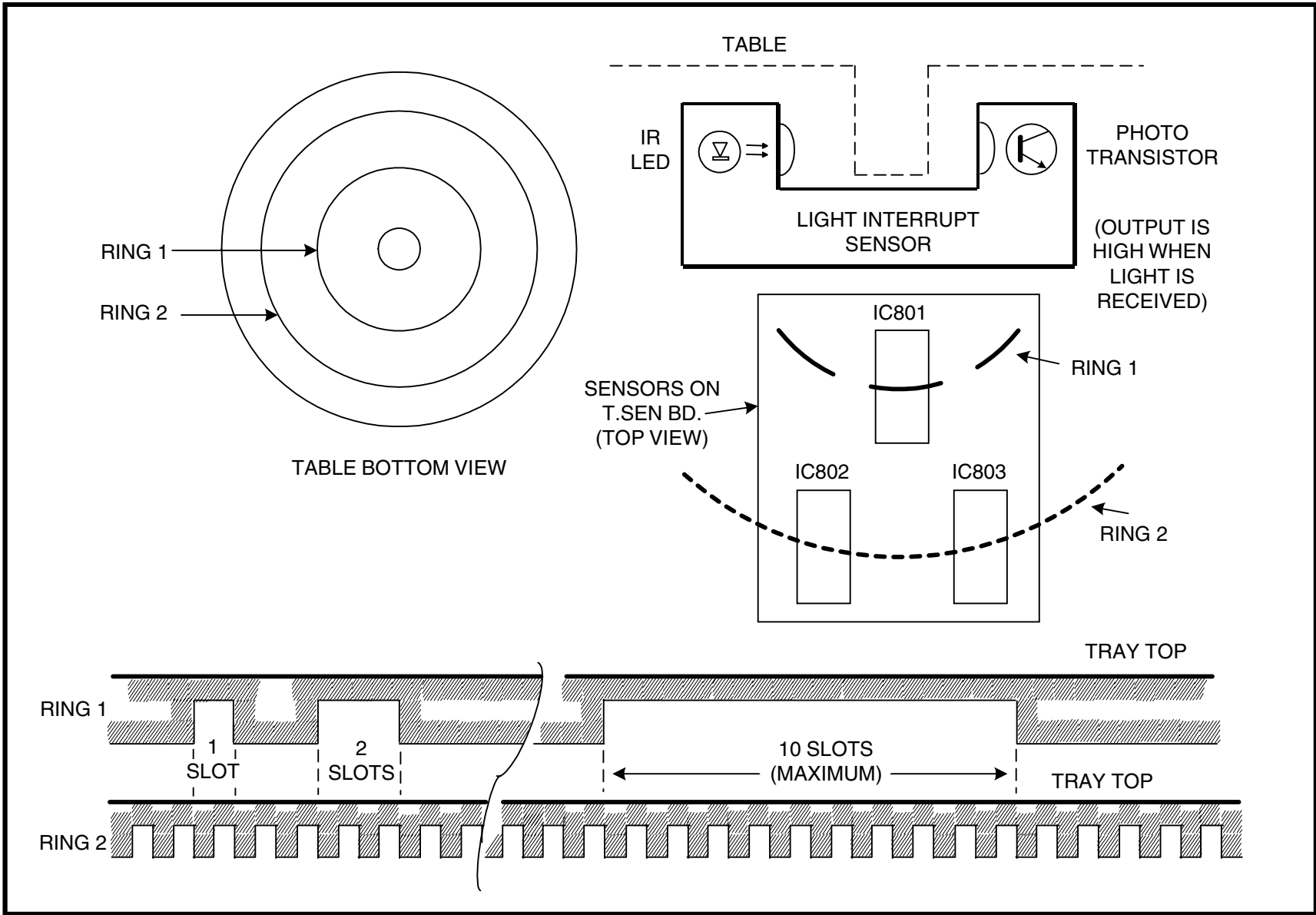

TRAY TABLE POSITIONING

5A122 1246 6/29/00

Table Motor Drive

Syscon IC501 drives the Disc's Tray Table. IC501 receives information from three tray table position sensors and the front panel rotary encoder knob to determine where the tray is and where to stop.

Front Panel Rotary Encoder

Operation

At the front panel there is a large knob that is used to select discs. The knob is connected to a rotary encoder switch on the jog board behind the knob. When the knob is turned to the next detent position, the display shows the information on the next disc in the tray. If that disc is desired, the same encoder button is pressed ("Enter") and that disc is accessed. When the disc door is open, the rotary encoder rotates the tray to any disc slot position, permitting the user to load discs. The FL display tube displays the same disc slot number marked on the tray at the opened door. With the door closed, the display tube shows the disc slot facing the CD Mechanism.

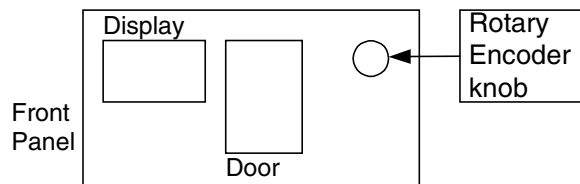

The rotary encoder switch is connected to Syscon at IC501/pins 42 and 43 respectively. At the encoder itself there are three contacts for the rotary encoder and two for the enter button. In the detent position, pin 1 is connected to pin 2 (ground). In the neutral position (in-between detents), pin 3 is connected to pin 2.

Rotary
Encoder
rear view
3 2 1

Direction of Rotation

The encoder is constructed so its direction from the detent position can be determined by IC501. In the detent position, pin 1 is grounded. In the neutral position, pin 3 is grounded. When turning the encoder knob in the CCW direction, both pins 1 and 3 are momentarily grounded before pin 1 is ungrounded ("make before break") in neutral. When turning the encoder knob CW, both pins 1 and 3 are open circuited before pin 3 is grounded in neutral. This is how IC501 determines the direction the user has turned the knob and rotates the tray accordingly.

Tray Table Position Sensors

Three sensors monitor the gaps in the tray table's rings to determine home position. Sensors IC802 and IC803 are used to determine the center of each disc slot. Sensors IC801 and the composite signal from IC802 and IC803 are used to determine where the tray is positioned.

For testing purposes, when the tray table is in a detent position, sensors IC802 and IC803 should output a HIGH at CN506/pins 1 and 2. Sensor IC801 outputs a HIGH when certain disc slot positions have been selected. The chart lists the disc positions IC801 will output a high in the current 200 disc changers.

With the door open, you can rotate rotary encoder and verify the disc positions in case the chassis has been bent or incorrectly aligned.

Disc positions when IC801 Output = HIGH (CN506/4)	
Disc Positions (# displayed on the tray)	Number of disc slots
10-18	8
30-39	9
50-60	10
70-71	1
90-92	2
110-113	3
130-134	4
150-155	5
170-176	6
190-197	7

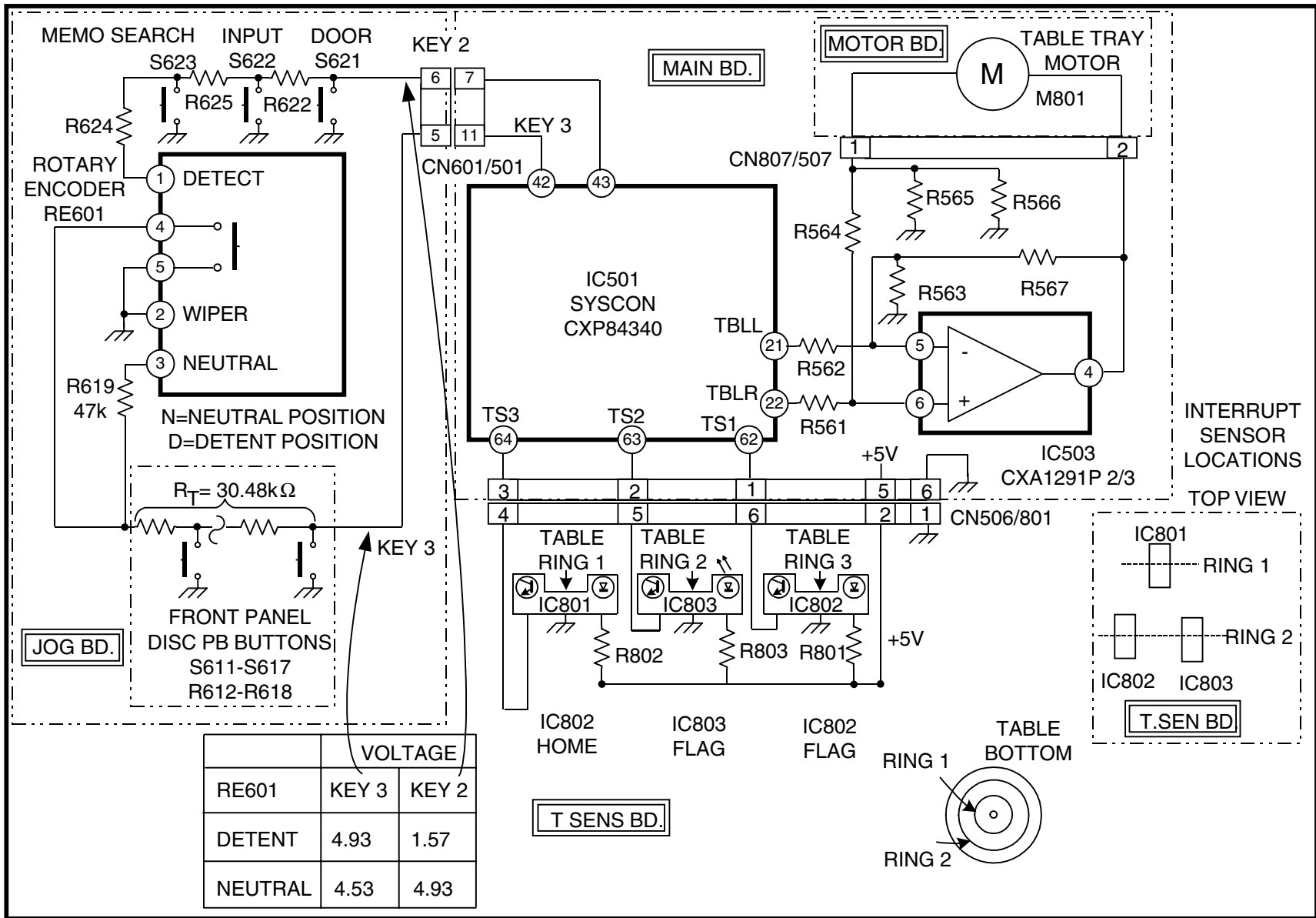

TABLE MOTOR DRIVE

4A122 1244 7/5/00

Tray Table Motor Drive

Syscon IC501 drives the motor that rotates the tray table. The following voltages output IC501 and IC503 to move the table in the direction viewed from the top.

Tray Table Drive Voltages					
Table Movement	IC501/pin		IC503/pin		
	21	22	6	5	4
Stop	0	0	0	0	0
CW	0	3.27	0.44	.45	5.37
CCW	3.27	0	0.044	0.042	-5.22

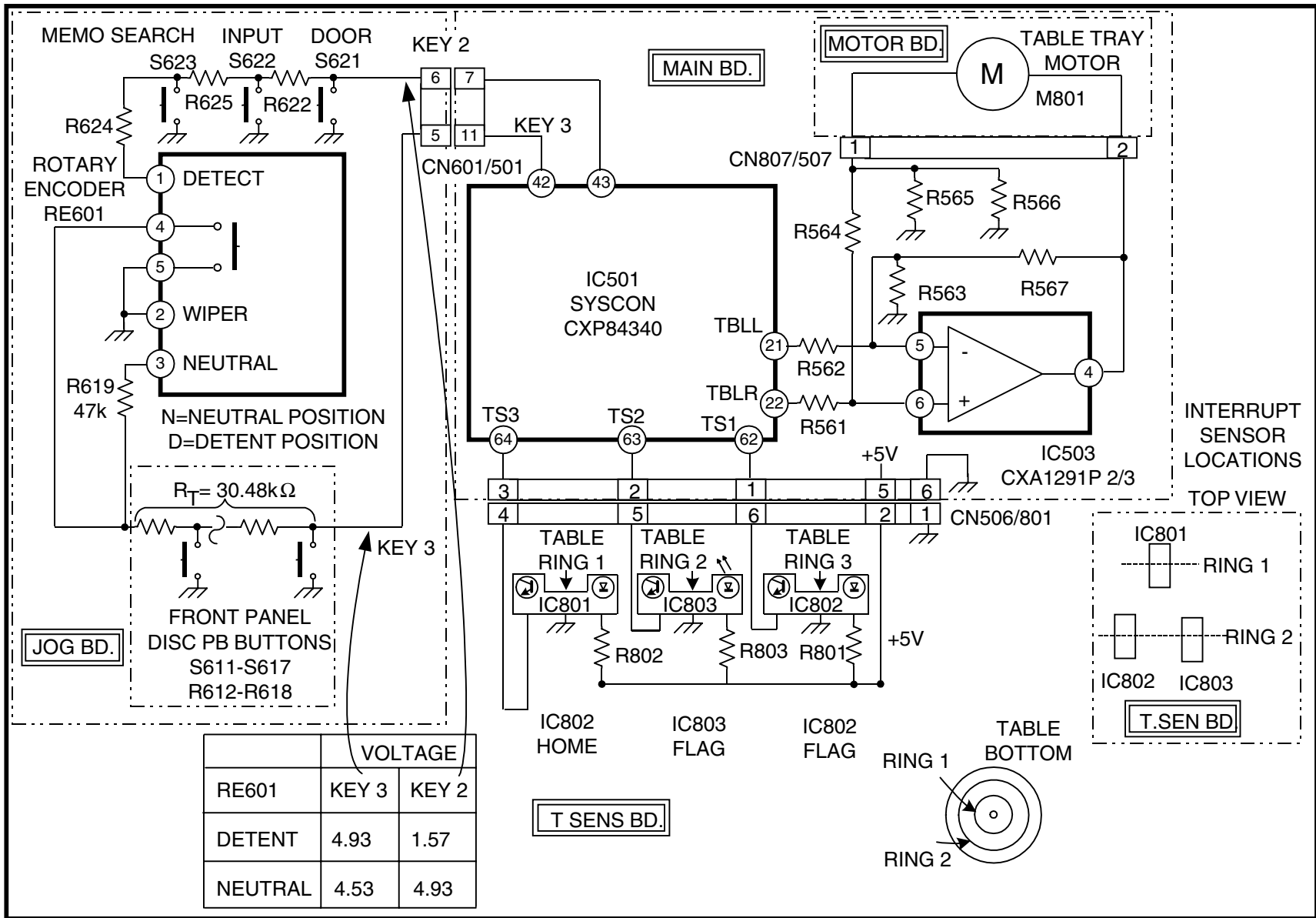

TABLE MOTOR DRIVE

4A122 1244 7/5/00

CD Allocation & Label Storage

Syscon IC501 has its built-in memory to remember if the door was open or closed, whether the disc was chucked or unchucked, and what order of songs to play (program play). This information is lost when the CD Changer is turned OFF. For other items that have to be remembered, IC501 uses an external static (S-RAM) memory IC502, powered by C522 when the changer is OFF.

IC502 stores the following information:

- Keeps track of what tray table slots have discs
- Stores disc slot number currently in use
- Groups discs (maximum of eight discs per group)
- Stores a name for each disc (Label)
- Logs tracks on a disc to be skipped (not played)

S-RAM Operation

IC502 is an S-Ram that stores bits of data using low power CMOS logic gates. A one-Farad capacitor, C522, provides power to IC502 when the CD Changer is turned OFF, preventing the loss of data for up to a month. When the CD Changer is ON, Syscon IC501 can read or write into each location of the memory by first enabling IC502 (CE = LOW), addressing a memory location, selecting read (WE = HIGH) or write (WE = LOW), and finally reading or writing the information. This S-RAM stores the information 8 bits at a time so a single address location reads or writes a Byte of data (8 bits).

Writing to Memory

The memory writing operation can be seen in the first scope shot. It was taken as the disc door is closing and the tray is rotating (press the Close Door button). At this time, every disc slot is being checked for discs as the tray rotates. If the memory information does not agree with the contents of the disc slot, the memory is rewritten to with the current information.

Channel 1 shows that S-RAM IC502 is enabled at power ON. Only one of the 14 address lines is represented in channel 2. As the tray rotates, IC501 sends its corresponding address to IC502.

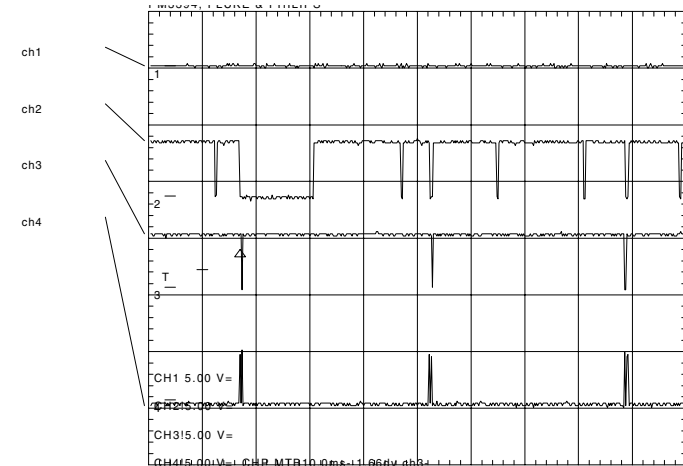

Syscon Checking the Tray for Discs		
Channel	Name	IC502/pin
1.	CE (chip enable - low)	20
2.	1 of 14 Address lines	27
3.	WE (write enable - low)	4
4.	1 of 8 Data lines	15
Time base = 10msec/div		

At each address location, the data is read while the write enable line (WE = Ch 3) is HIGH. This data (Ch 4) is sent to Syscon IC501 for comparison. Meanwhile, disc detector Q801 will place a HIGH at IC501/pin 38 if there is NO disc at that slot location. If the memory also shows there is NO disc at this location, the two pieces of information agree and there is no change to the memory data. If they do not, WE goes LOW (Ch 3) while still at that same address location (Ch 2) and the new data from IC501/pin 38 is placed into memory.

Reading from Memory

The memory reading operation can be seen in the second scope shot. This was taken with no disc chucked and the rotary encoder knob turned to move the tray table. At each tray slot the memory location was read to see if there is a disc at that slot.

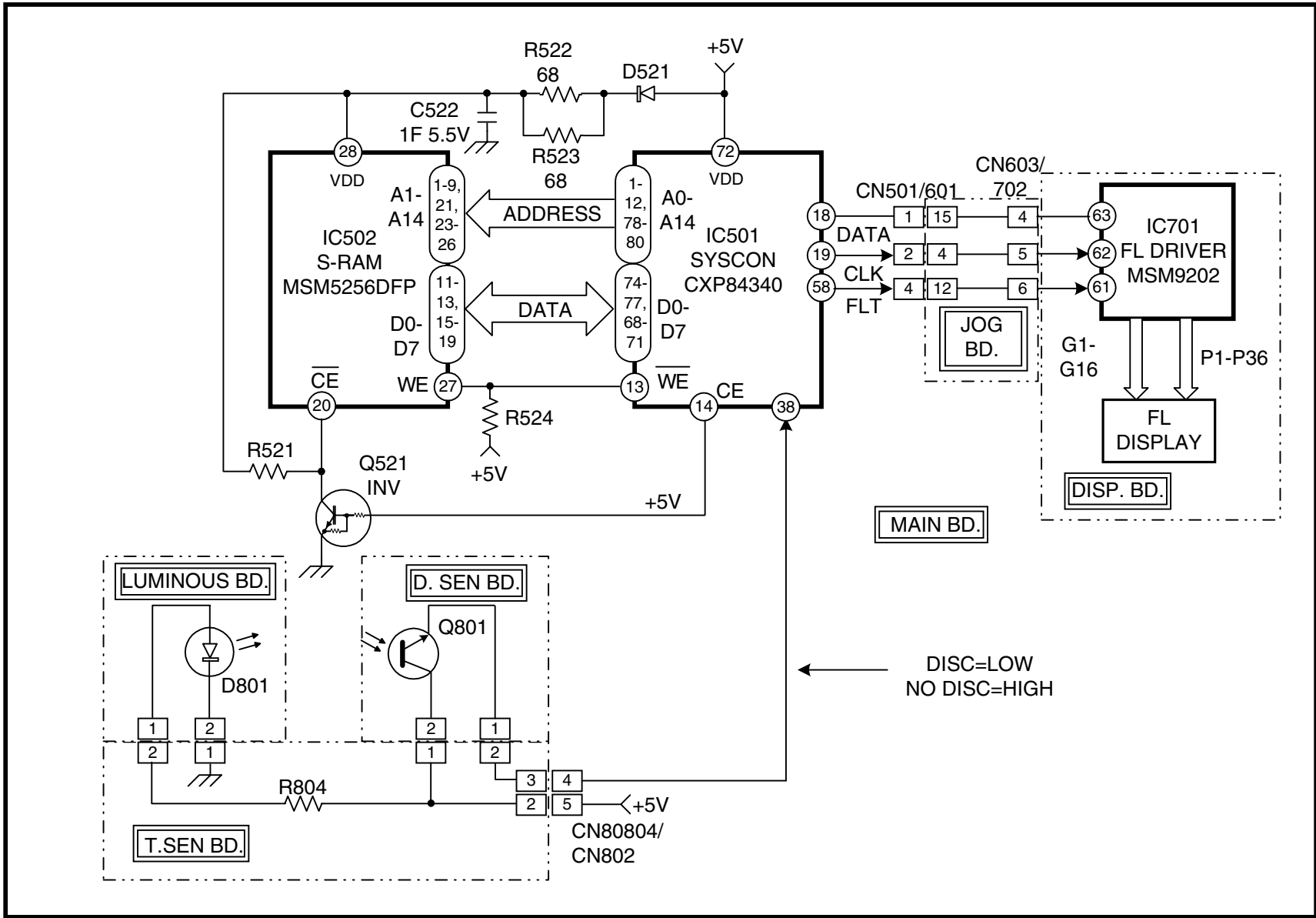

CD LOCATION & LABEL STORAGE

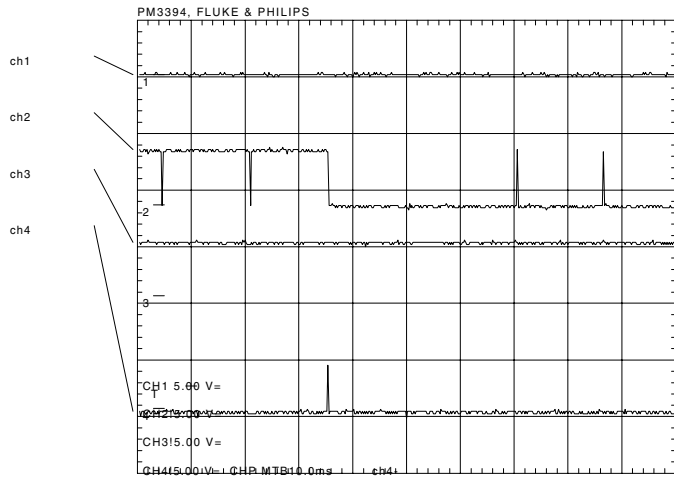

Reading the Tray Table Information		
Channel	Name	IC502/pin
1.	CE (chip enable - low)	20
2.	1 of 14 Address lines	4
3.	WE (write enable - low)	27
4.	1 of 8 Data lines	15
Time base = 10msec/div		

Note that the Read/Write channel 3 waveform remains HIGH, indicating that only the memory reading operation takes place. Label and disc availability data outputs as each tray table slot was addressed. In this CD Changer example, there were no labels stored in memory so very little data is present at channel 4.

Display Information

When the door is closed and the rotary encoder is turned, the memory is checked for the next occupied slot location. As the tray moves the disc toward the CD Mechanism, the label information is output. At each tray slot location where there is a disc, the corresponding Label information is sent to Syscon IC501. IC501 reorganizes the data and sends the applicable information to the FL Display Driver IC701. If there was no label information, only the disc number is sent. The Display IC assigns

segments to display this information on the front panel display tube. The following waveforms show the data, clock and latch signals from IC501 to IC701 used to produce a display when powered on.

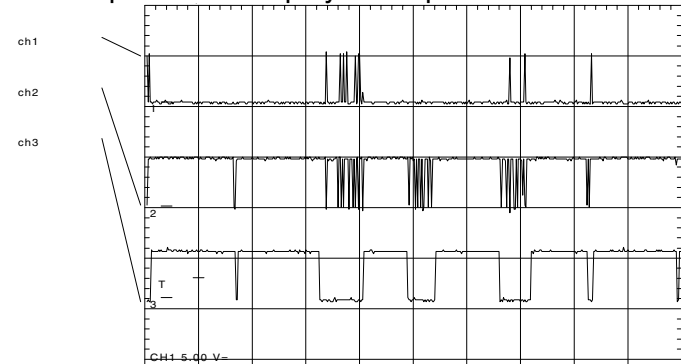

IC501- IC701 Communications (Power ON)		
Channel	Name	IC501/pin
1.	Data	1
2.	Clock	2
3.	Latch	4
Time base = 200msec/div		

Oddly, even when the CD Changer is turned OFF, Syscon is sending data, clock and latch signals into FL Driver IC701.

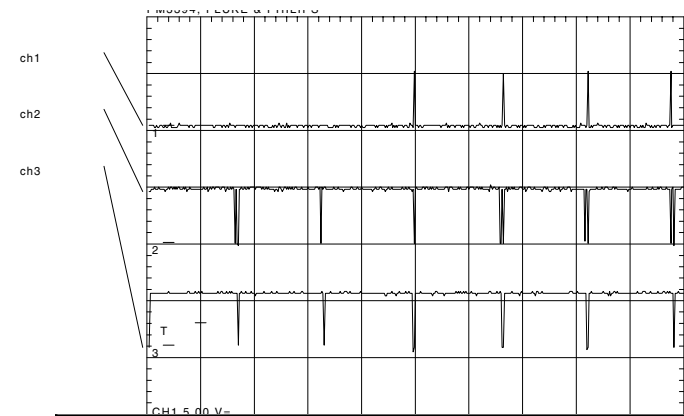

IC501- IC701 Communications (Power OFF)

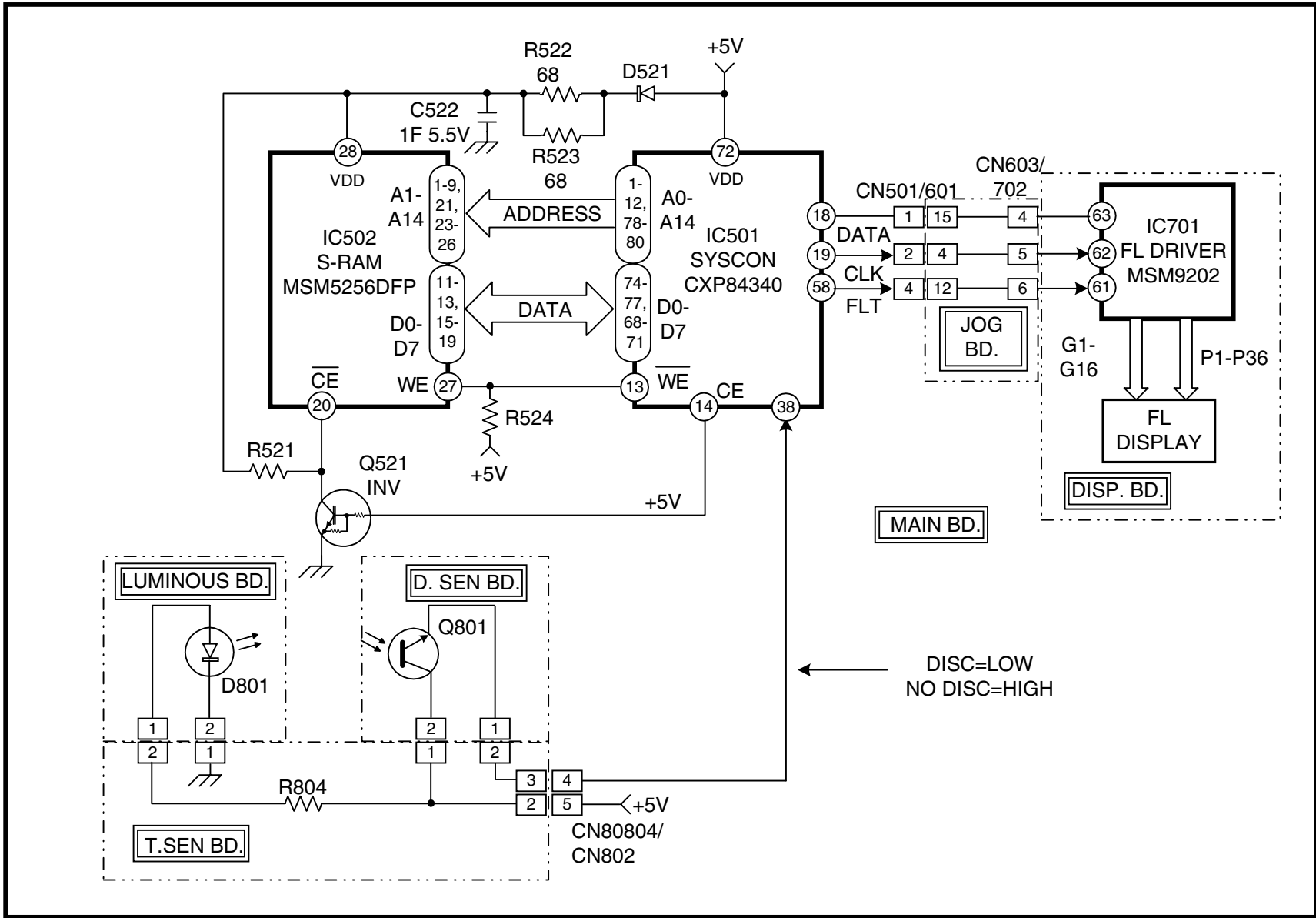

CD LOCATION & LABEL STORAGE

Disc Loading Drive

The purpose of the Disc Loading Drive stage is to rotate a cam that moves levers to:

- Lock the tray table (after it has stopped)
- Grasp the disc from the tray table
- Guide the CD into the CD Mechanism
- Clamp the CD onto the spindle motor shaft (chucking)
- Release the CD when the cam reaches the end of travel.

Once the tray table has stopped, the Disc Loading Drive has the job of getting the disc out of the tray table and placing it into the CD Mechanism for play. From an electronic point of view, all that has to be done is to rotate the Disc Loading Motor. The remainder is mechanical and is addressed in the overview and during alignment.

Operation

The electrical operation of this stage is similar to the Door Motor Drive. After disc is placed on the tray table, Syscon IC501 positions the disc in front of the CD Mechanism. The loading motor is powered to load the disc into the CD Mechanism.

Loading Motor Drive Voltage			
Cam Direction / Function	IC501/pin 26	IC501/pin 27	IC503/pin 3
CW / Chucking	3.1V	0V	3.4V
CCW / Unchucking	0V	3.1V	-3.0V

Motor Stop

Just before the cam reaches the end of travel, it toggles the S801 switch on the L. SW Board. The switch grounds IC501/pin 55 or 67 depending upon the direction of rotation. A LOW voltage instructs IC501 to discontinue the loading motor drive voltage. The loading motor stops.

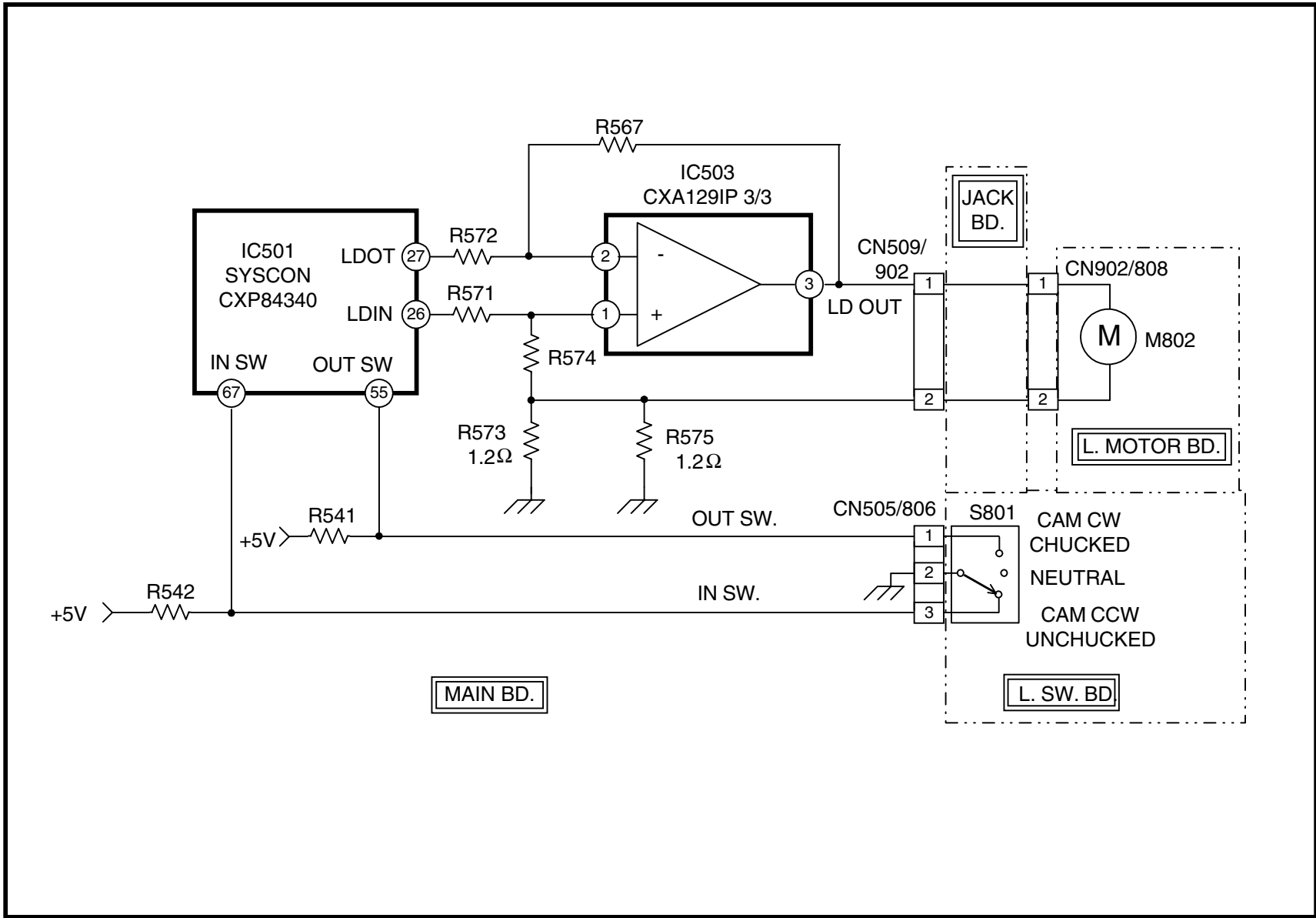

DISC LOADING DRIVE

6A122 1247 6/29/00

Optical Pickup

The Optical pick up assembly is the single most complicated device in the CD player. The Optical assembly has several parts:

- The laser and objective lens
- Focus coil
- Tracking coil
- Detector assembly

Each part has a role in the playback of the disc information.

The Laser and Lens

The laser diode is powered by a regulated voltage (LD). Within the assembly is a photodiode that monitors the laser light intensity. This information (PD) is fed back to the circuitry to regulate the LD drive voltage.

The laser light is channeled through an objective lens towards the CD. The convex objective lens funnels the laser beam into a focused point near where the disc's shiny information layer should be.

Focus Coil

The objective lens has a coil of wire attached to it in two planes. A stationary piece of metal is adjacent to it for magnetic reference. As current flows through the focus coil, the lens is moved either toward or away from the disc depending upon the direction of the current. Therefore, applying sufficient current to this coil will move the lens and its focus point to the disc's information layer.

Tracking Coil

The tracking coil on the objective lens is perpendicular to the focus coil. Current through this coil moves the lens and the laser beam to one side or another. This movement keeps the laser beam on the spiral track as the disc rotates. When the tracking coil has moved the lens to the limit, the sled moves the optical assembly to follow the spiral track. This re-centers the lens within limits and the tracking coil can continue to follow the track once again.

Detector Outputs

Laser light striking the information layer of the disc is modulated by the data and returned to the detector area next to the laser diode. Detectors A-F receive the light, amplify and output this signal to the external RF amplifier to produce derived signals.

Optical Assembly Output Applications		
Output	Derived signal	Purpose
Detectors A-D	RFO (RF Output)	Audio, Spindle motor lock
Detectors A-D	FE (focus error)	Focus coil correction signal
Detector E & F	TE (tracking error)	Tacking and sled motor correction signal

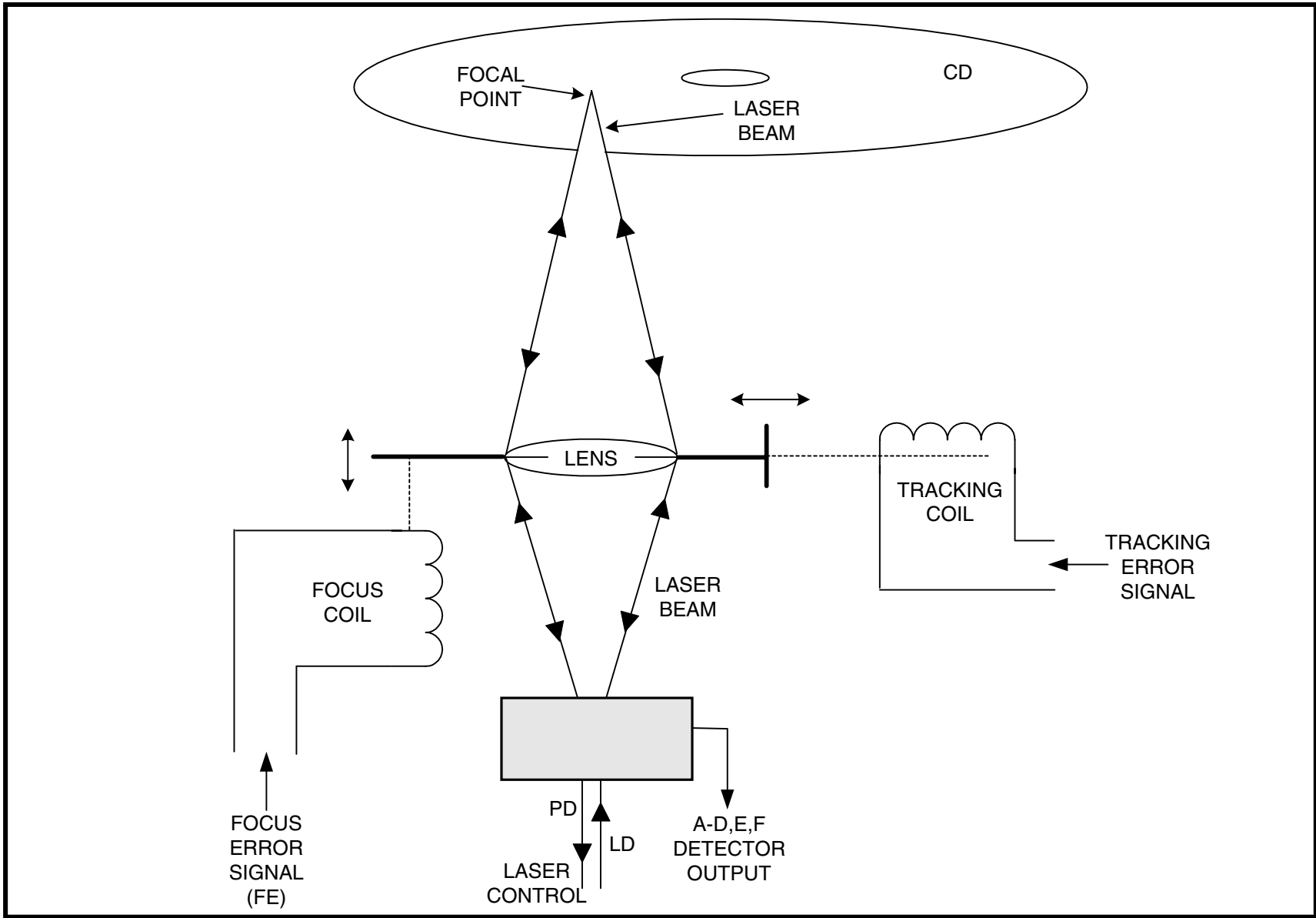

OPTICAL PICKUP

7A122 1245

7/7/00

Servo / Audio Processing Block

In order for the CD player to produce audio, the servo section must control the laser beam so it can recover the digital data from the disc. Once the data is stable and output at a constant rate, it can be processed and returned to analog audio.

Servo Block

A chain of events must occur for the laser to read the disc's data. The sequence is as follows:

CD Play Sequence		
Operation	Purpose	Check
1. Optical block returns to home position	Begins reading the CD at the TOC area	Sled moves the block toward spindle motor at Power ON
2. Laser turns ON	To read the disc data	Laser power meter data
3. Focus search / servo ON	Find and maintain focus on the disc	Scope at the FOK test point. Disc spins after focus is found.
4. Tracking servo ON	Follow the disc's spiral information track	Scope at the TE test point
5. Spindle servo ON	Spin the disc so the data is output at a constant rate	Disc spins. Lock test point = HIGH when data rate controls the speed.
6. CD Data to analog conversion	Music recovery (processing)	C2PO test point = LOW when no recovery errors. Audio output

When there is a break in the sequence, music cannot be recovered. Examining the waveform at test points can test each servo.

Sled Motor

When the CD Changer is turned ON (no disc chucked), the tray table rotates to determine its position. Within the CD mechanism, the sled motor drives the optical assembly toward the spindle motor until the limit switch is closed. If this switch doesn't close, the laser and focus search will not take place and the CD will not spin.

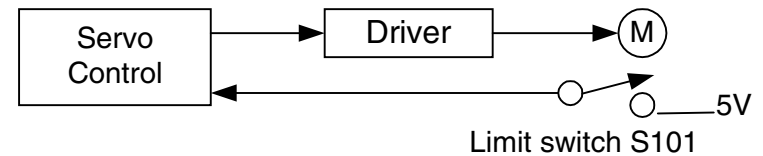

Focus Search

The focus operation is divided into search and servo parts. Servo Control starts focus search when it knows the sled is at home position (S101) and the CD Mechanism enters the chucked position (cam switch S801).

Servo Control makes a ramp voltage used to drive the objective lens through its full length of travel, moving the distant focus point along with it.

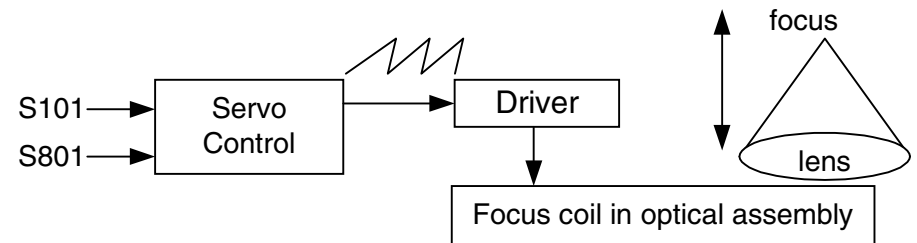

Focus Servo

When the laser focuses on the disc's reflective information layer, light is returned to the optical assembly detectors. The A-D detectors are output to the RF Amplifier. The RF stage not only amplifies the level but also matrixes the signals to produce FE and RFO signals. FE is an output signal used to identify and maintain focus when finally applied to the focus coil of the optical assembly. RFO is the main signal that will be processed into audio if the servos all work.

Servo Control receives the FE signal and uses it with RFO to determine when focus has been found during focus search. Focus is found when the FOK (test point) goes HIGH. This is when Servo Control replaces the

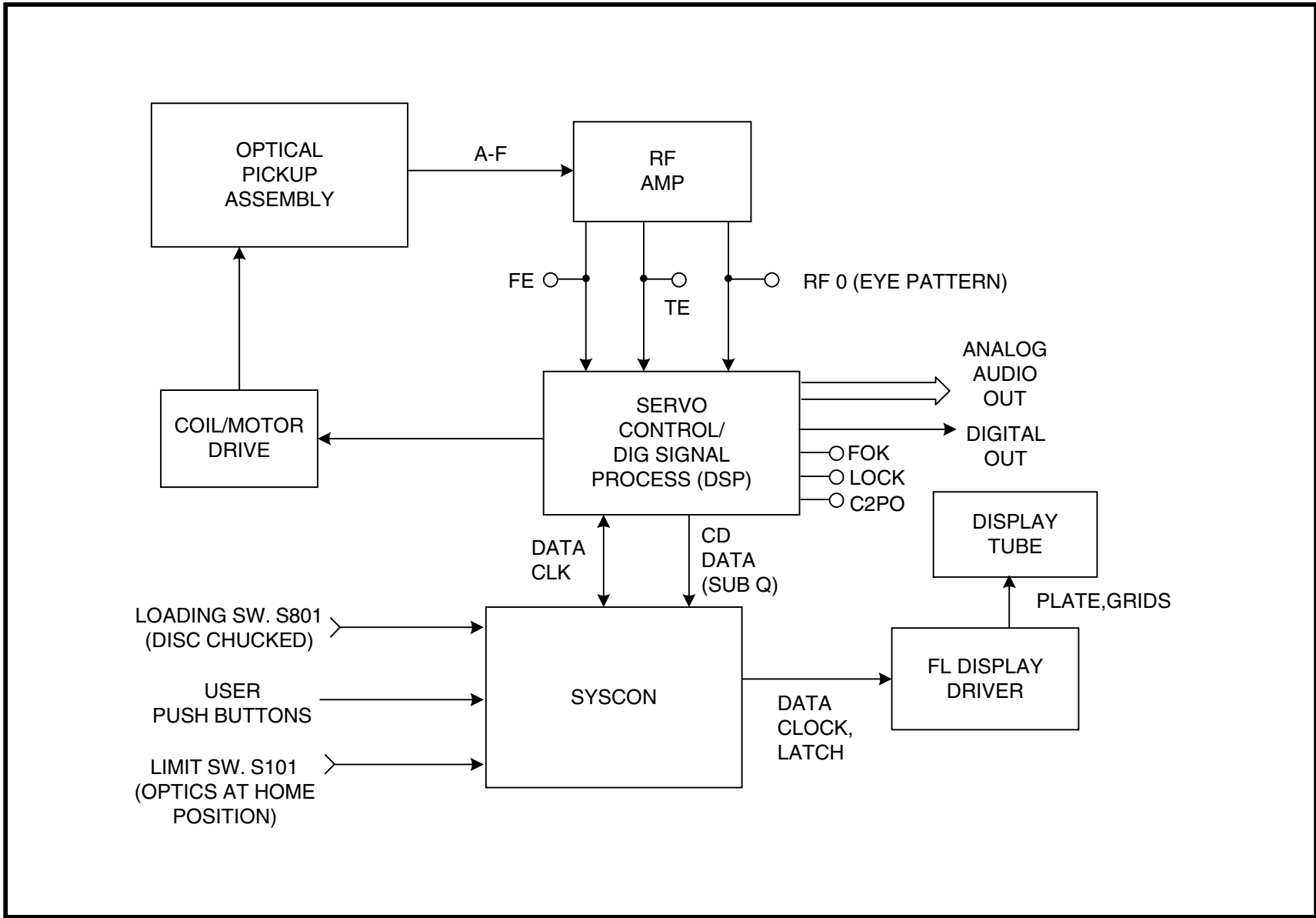

SERVO/AUDIO PROCESS BLOCK

9A122 1251 6/29/00

search voltage with an amplified FE voltage. The FEO output is sent to a current driver IC. This IC drives the optical assembly's focus coil to maintain focus on the disc during playback.

The FE and RFO waveforms can be used in troubleshooting to determine if there is a signal output the optical assembly. The FOK test point can be used to determine if the quality of the two signals is sufficient to find focus.

Tracking Servo

Once focus is found (FOK goes HIGH), the spindle motor starts and the tracking servo loop is closed. The tracking servo moves the objective lens so the laser can follow the disc's information track.

The center of the disc's track is identified using optical assembly detectors E & F. The RF Amp converts these two input signals into a tracking error (TE) correction signal that is sent to Servo Control. Servo control amplifies the TE input and closes the servo loop switch, outputting the amplified tracking error signal (TEO).

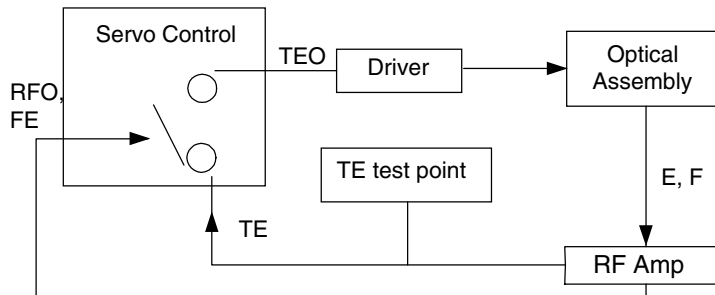

The driver IC that receives TEO supplies current to generate a magnetic field in the tracking coil. The coil moves the objective lens (with laser beam) so the beam follows (tracks) the disc data.

Spindle Motor

Like the focus servo, the spindle motor servo has two modes of operation. As soon as focus is found, the spindle motor is kick started and runs to approximately the correct speed. This is the first mode of the spindle motor operation.

The second mode comes some time later after the tracking servo operates. This is when the RFO data is reliable and can be used to govern the spindle motor speed. This second mode of operation cannot be seen because the motor is already running. However when the motor is linked to the disc data, the LOCK test point goes HIGH.

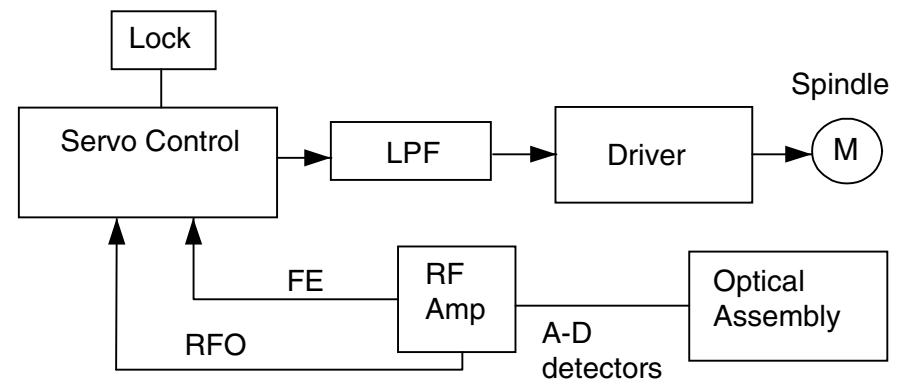

Audio Block

Once the spindle motor is locked to the data (LOCK = HIGH), the data is reliable enough to be audio processed. The disc data comes into Servo Control as RFO. It is error corrected, digitally reconstructed and output as a digital signal to the rear panel jack. The digital signal is also converted to analog within Servo Control and delivered to the rear panel L & R jacks.

While audio is output, the front panel display is receiving the CD track and playback time information. Servo Control sends Sub Q digital data (and clock) to Syscon for compiling and interpreting. The resultant information is sent to the FL Display Driver as Data, Clock and Latch signals. The Display driver determines what display segments of the tube have to be lit to produce the desired time and track characters.

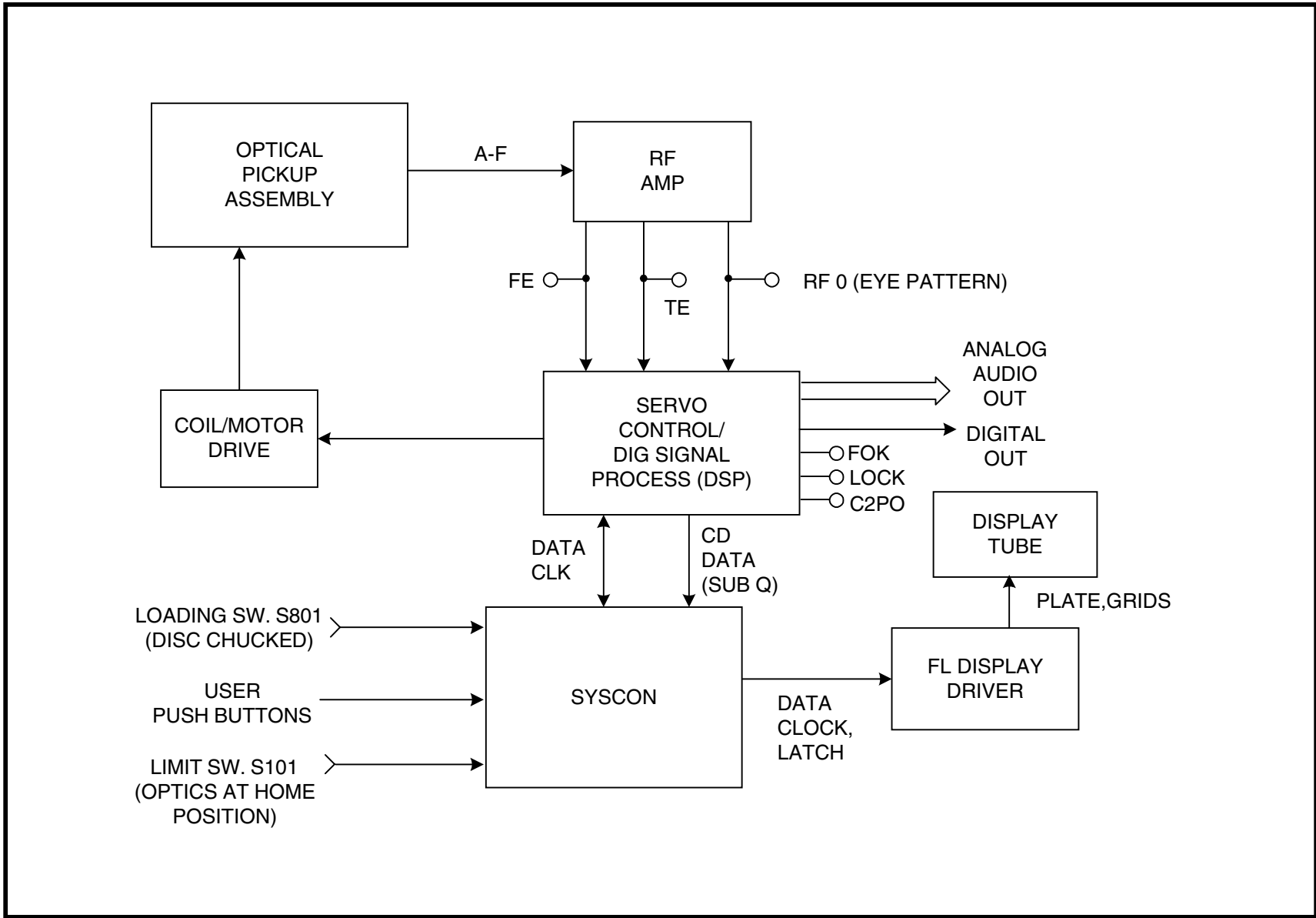

SERVO/AUDIO PROCESS BLOCK

9A122 1251 6/29/00

Servo Processing

There are several main servos that can be tested for normal operation.

Sled Motor Drive

When the power On button is pressed, the sled motor is driven inward until the optical assembly that is connected to it closes the S101 limit switch. This closure places 5V at IC101/pin 27 so it may turn on the servos to begin the disc playback sequence.

Laser

The Laser servo is the first to be turned on when the S101 limit switch is closed and the loading switch is in the (disc) chucked position. IC101/pin 14 outputs a HIGH (5V) to RF Amp IC103/pin 22 to enable the laser servo. The laser diode and light sampling photodiode are in the optical assembly and the remainder of the regulating circuit is in IC103 with Q101 as an external amplifier. IC103/pin 3 drops from 5V to about 3V to turn on the laser. Q101 turns on, supplying current to the laser diode at pin 10 of the optical pick-up ribbon cable connector. The laser diode will turn on when there is sufficient current to drop about 1.8 to 2.2V at the diode.

Precautions

Although not recommended, if you must apply an external voltage to check the diode, you must current limit this with a 1k-ohm resistor to prevent laser diode damage. NEVER LOOK AT THE LASER DIODE LIGHT. Use a laser power meter to measure the intensity of this class 1 laser. Also, if your ohmmeter outputs more than 2V, do not check the laser diode for diode continuity.

The laser intensity is monitored by a photo diode in the optical assembly. The PD output into IC103/pin 4 is used to regulate the LD output from pin 3.

Laser Diode Control Voltages			
Laser	IC103/pin 3	Q101/Collector	IC103/pin 4
OFF	4.76V	0V	0V
ON	3.17V	1.98V	0.116V

Focus

The focus search operation is also initiated when the disc is chucked in the CD Mechanism (S801 not shown) and the limit switch (S101) is closed. Servo Control IC101 generates the electrical signal that results in the visible lens movement in the optical assembly.

The changeover from search to servo lock occurs when RFO signal is present and the FE "S curve" shaped signal voltage crosses to/through Vc voltage (half of Vcc. Vc = 2.5V). At this recognition time, FOK at IC101/pin 24 goes HIGH to mark the transition to servo operation. If this transition were inhibited so only the search operation took place, the RFO and FE waveforms would look like this:

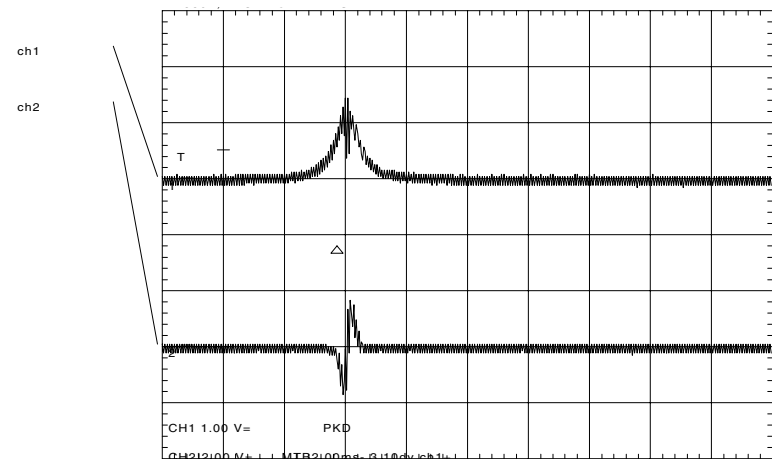

S Curve focus Search (Changer is in ADJust Test Mode)

Channel	Signal Name	Location
1	RFO test point	IC103/pin 16
2	FE test point	IC103/pin 14
Time base = 2msec/div		
Scope ground is taken at Vc (IC103/pin 12)		

Normally as the FE (Ch 2) signal would cross through Vc, IC101 would start focus servo and the top half of the FE waveform (above the Vc base line) would never take place.

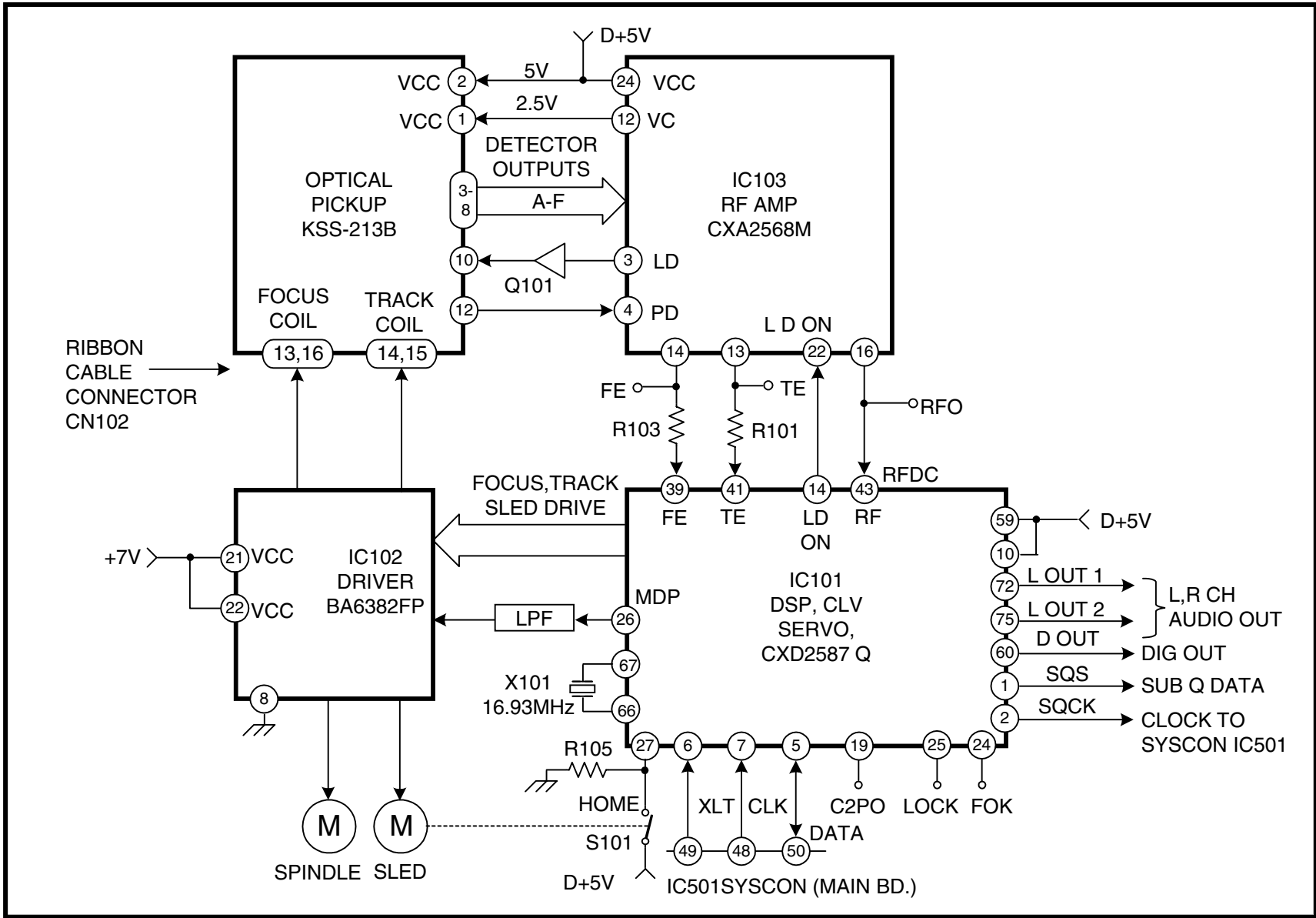

SERVO PROCESSING

Tracking Servo

The tracking servo is turned on after focus is found (FOK = HIGH). This servo results in a periodic track correction signal that looks like about 400mV of noise at the TE test point.

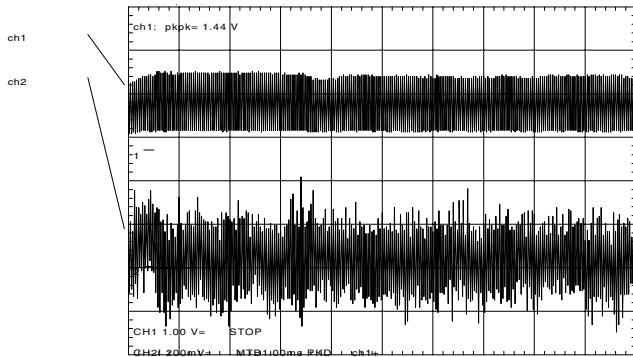

Normal CD Playback		
Channel	Signal Name	Location
1	RFO test point	IC103/pin 16
2	TE test point	IC103/pin 13
Time base = 1msec/div		
Scope ground is taken at Vc (IC103/pin 12)		

When the tracking loop is open, the laser is no longer following the data track. In the following scope shot, the RFO waveform in channel 1 shows the laser is seeing alternate areas of RF data (teeth) and no data (gaps). Channel 2 shows there is TE correction signal generated from IC103/pin 13, but it is not reaching the tracking coil for correction.

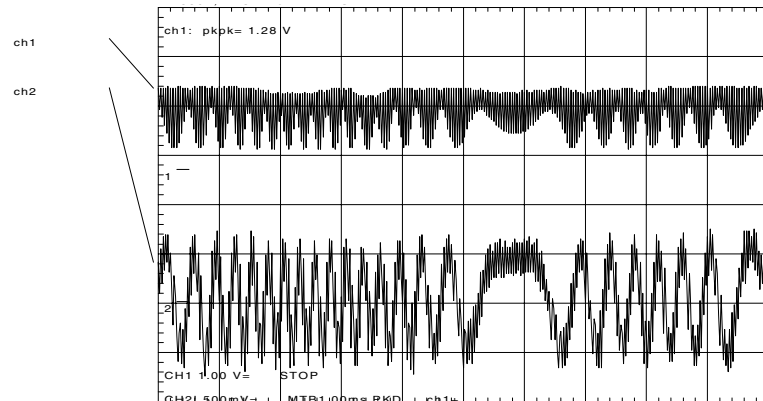

Defective Tracking Servo Waveforms		
Channel	Signal Name	Location
1	RFO test point	IC103/pin 16
2	TE test point	IC103/pin 13
Time base = 100msec/div		
Scope ground is taken at Vc (IC103/pin 12)		

Spindle Servo

Although the spindle motor has started when focus was found (FOK = HIGH), its lock onto the data does not occur until about 800msec later. At that time the LOCK signal goes HIGH.

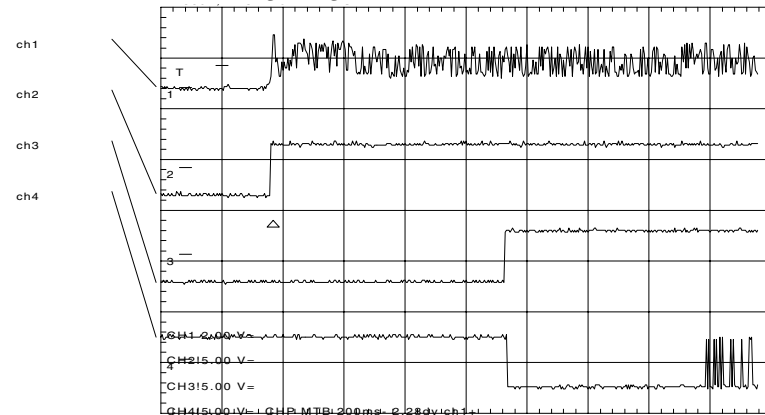

CD Playback Starting		
Channel	Signal Name	Location
1	RFO	IC103/pin 16
2	FOK test point	IC101/pin 24
3	LOCK test point	IC101/pin 25
4	C2PO test point	IC101/pin 19
Time base = 200msec/div		
Scope ground is taken at Vc (IC103/pin 12)		

At this time, the RFO signal should be at least 1Vp-p (1.2Vp-p = normal) and the RFO waveform should be straight on top and bottom (no drop-outs).

Once the LOCK test point goes HIGH, the servos are all working and audio should output if that processing within IC101 is OK.

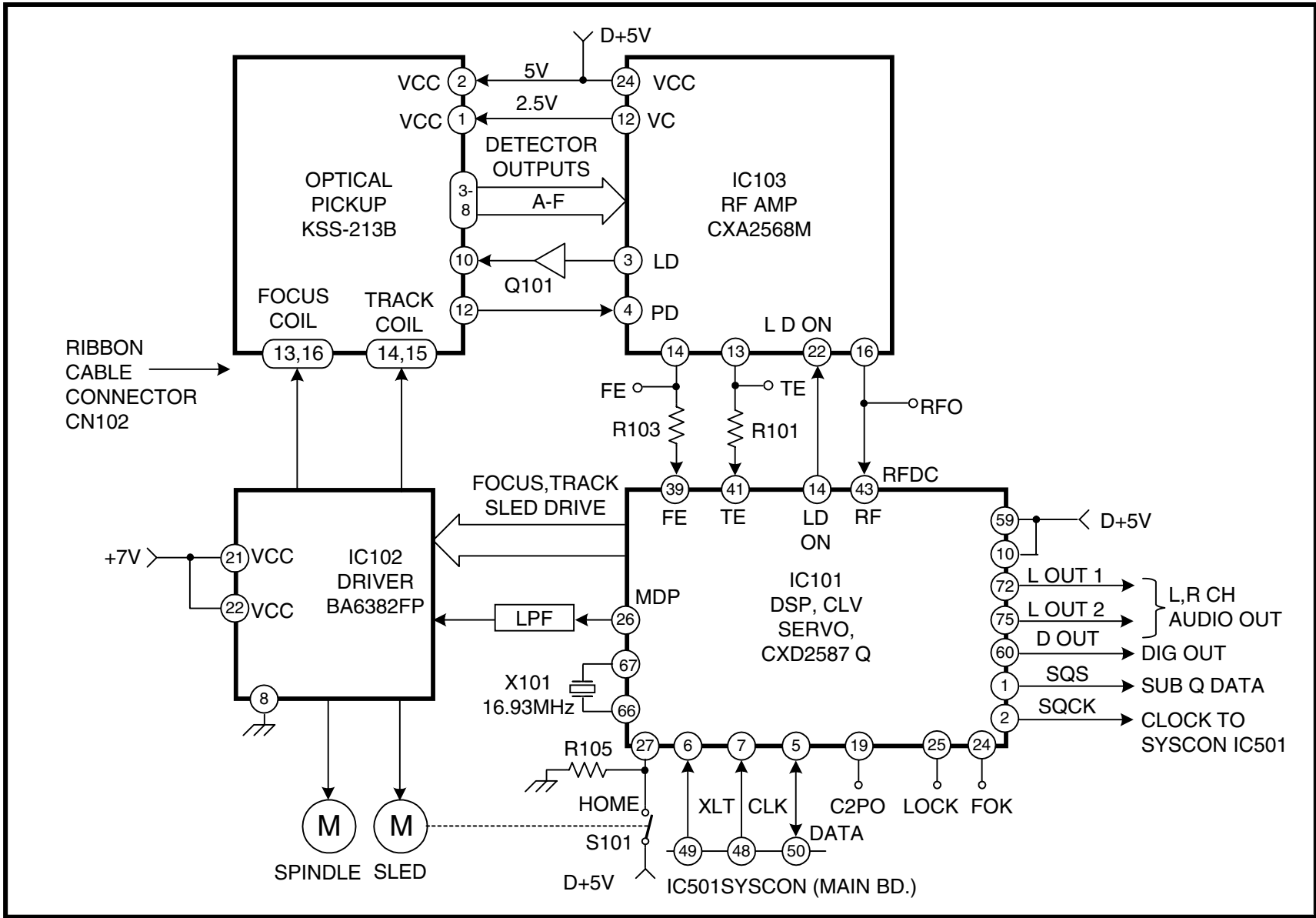

SERVO PROCESSING

Audio / Display Output

Analog Audio Output

The left and right channels of Servo Control IC101 are applied to amplifier IC401. Their outputs are AC coupled to the rear panel phono jacks. The following signal levels were measured using the Sony YEDS-18 test disc track #5 (10kHz mono, 0db).

IC401 voltages			
Measurement	Pin 2	Pin 3	Pin 1
DC	0V	0V	0V
AC	3Vp-p	3Vp-p	5Vp-p

Muting transistors Q325, Q327, and Q425 mute the output audio at power ON and OFF.

Digital Output

The digital output signal from Servo Control IC101/pin 60 is applied to IC901 at the rear panel of the changer. Inside IC901 is a visible LED in a plastic package that can connect to the consumer standard optical cable.

There is always a base waveform at the Digital Output pin 60 of IC101, producing an average DC voltage of 2.47Vdc. This waveform keeps the optical output LED lit (red) when the changer is powered ON.

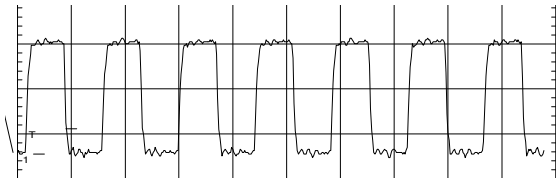

Digital Output Signal Power ON, No PB		
Name	Location	Frequency
Digital Output (electrical)	CN502/pin 10 (from IC101/pin 60)	1.4MHz
Time base = 0.5usec/div		

When a disc is played, the base frequency square wave is replaced with data.

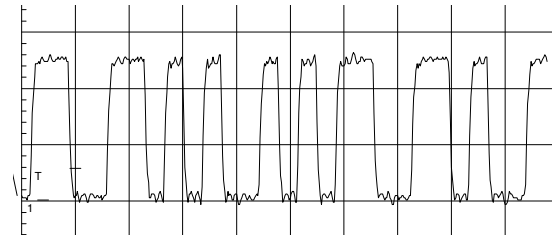

Digital Output Signal Power ON, Disc PB		
Name	Location	Frequency
Digital Output (electrical)	CN502/pin 10 (from IC101/pin 60)	data
Time base = 0.5usec/div		

Display

SQ data and clock from Servo Control IC101/pins 1 and 2 are applied to Syscon IC501 for processing. The results of this data will be the CD time, track, and name information applied to the FL display driver IC701. The SQ data and clock are only present when a disc is played.

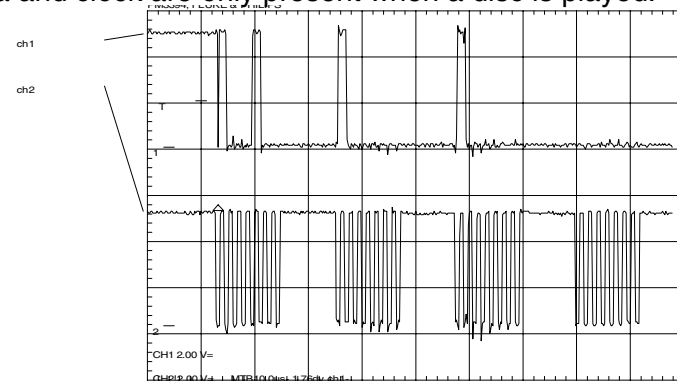

Disc PB track 1		
Channel	Name	Location
1	SQSO / Sub Q	CN502/pin 12
2	SQCK / SQCLK	CN502/pin 14
Time Base = 10usec/div		

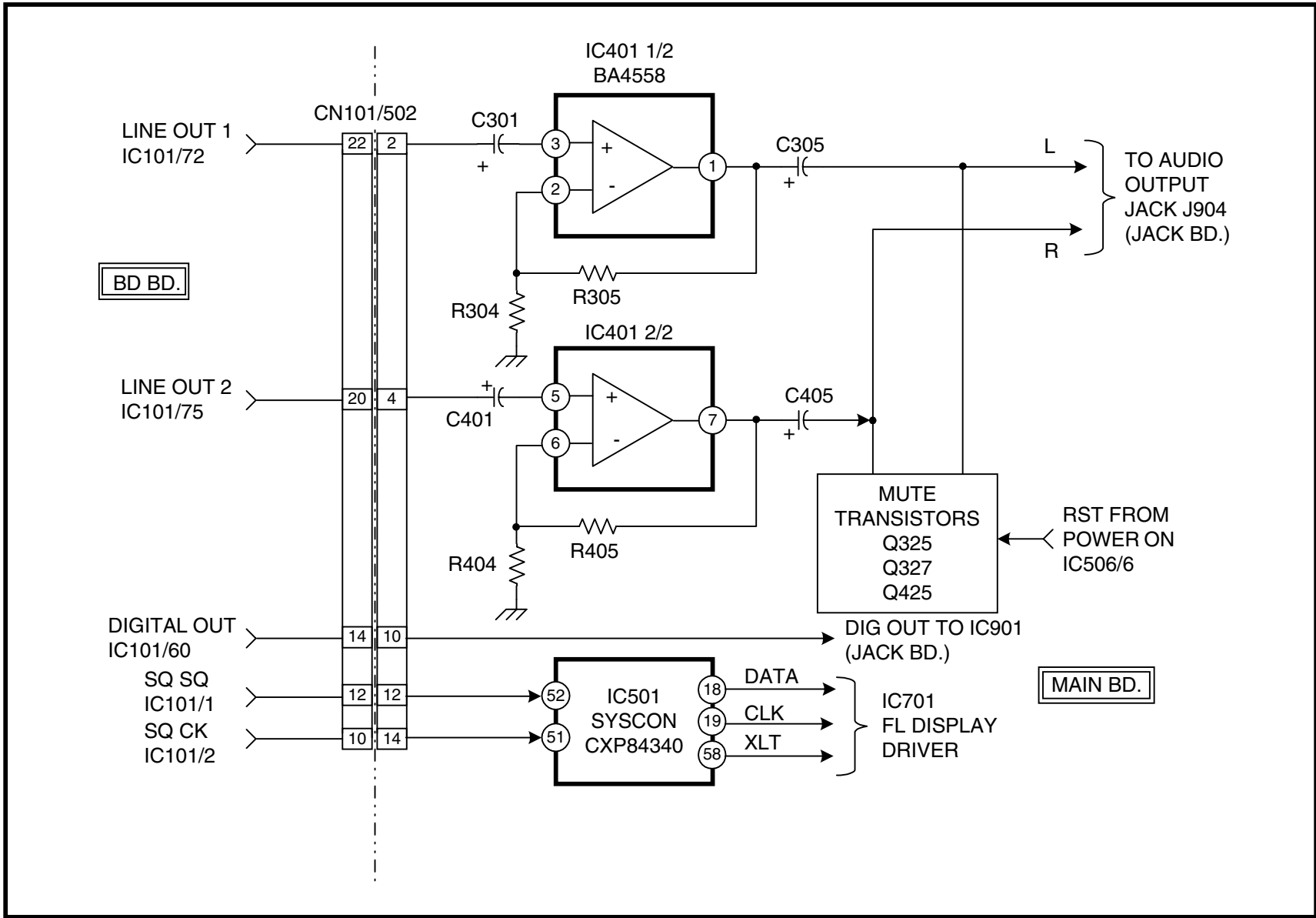

AUDIO/DISPLAY OUTPUT

11A122 1250 7/5/00

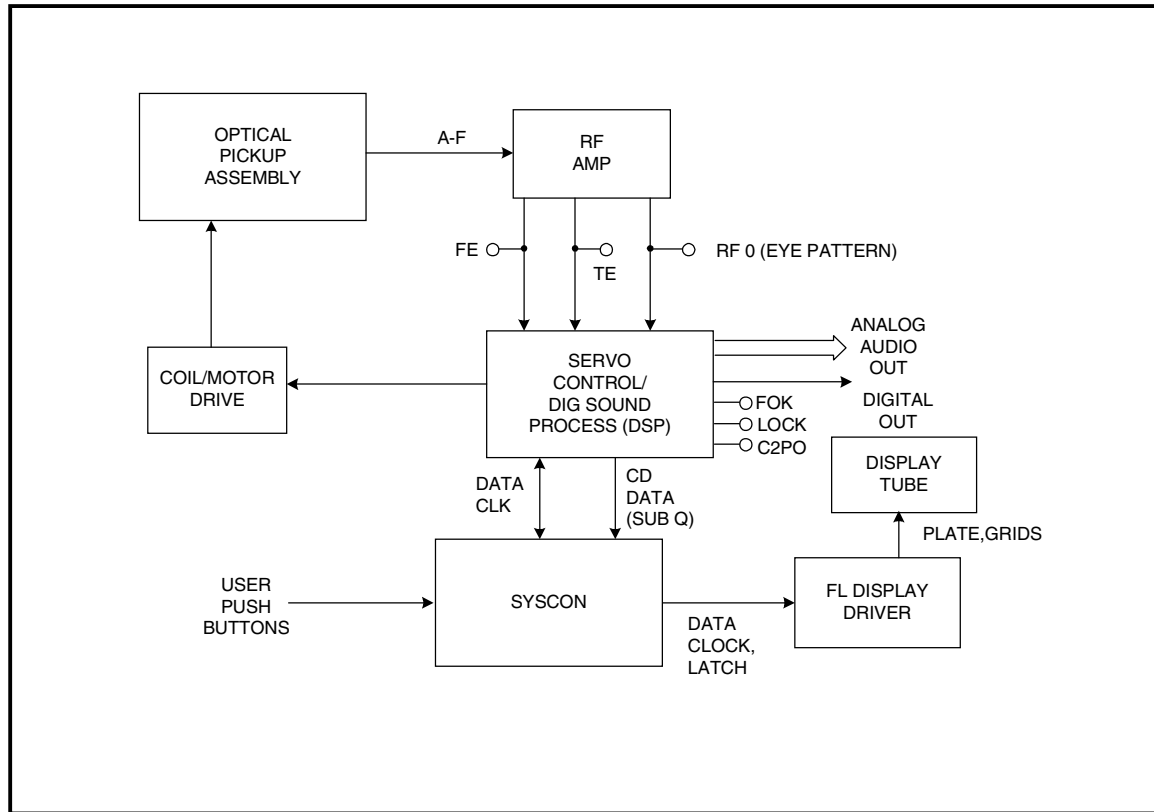

SERVO/AUDIO PROCESS BLOCK

9A122 1251 6/14/00



BD board - Old



BD board - New

Troubleshooting

The CD Changer can be divided into two main areas: The Changer mechanism that selects the disc from the tray table and the CD disc Playback mechanism that reads the track of information from the disc and produces audio.

The Changer mechanism periodically requires mechanical adjustment to compensate for wear of parts over a time. This will make sure the correct disc is identified and selected.

The Playback mechanism is more involved, requiring an understanding of the playback details for efficient repair.

Failures in the playback mechanism can be classified into these symptoms:

- Disc doesn't spin.
- Disc spins but doesn't read the disc's table of contents (TOC).
- No Audio.

Disc Doesn't Spin

Before the disc spins, the sled must be at home position, the laser must be turned on, and focus must be found. All of these things can be checked easily.

Sled

In the CD Mechanism, you will manually move the optical assembly away from home position. When you power up the CD changer, the sled motor will turn, moving the optical assembly to the limit switch. This proves the sled assembly is basically OK. As you move the gears make sure they move without binding. The limit switch must be tested with an ohmmeter. The sled check procedure is as follows:

1. Shut off power by pressing the POWER button if necessary.
2. Locate the large white gear in the CD Mechanism and rotate it so the optical assembly moves away from the spindle motor shaft (which is the home position).

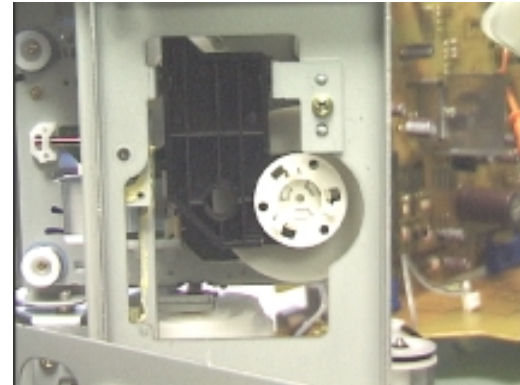

3. Press the POWER button and the optical assembly should return home. (The tray table should also rotate at this time.)

When the optical assembly reaches home it should close the limit switch and power to the sled motor will stop. The white gear should be free (unpowered), proving the limit switch is OK. You can also test the limit switch with an ohmmeter.

Laser

It is best to measure the laser brightness with the Leader model 8001 laser power meter. During focus search, the laser power is 0.03mW in this model CDP-CX235 200 disc CD changer. The procedure is:

1. Remove the magnet assembly by pulling it outward at a 2 o'clock direction.

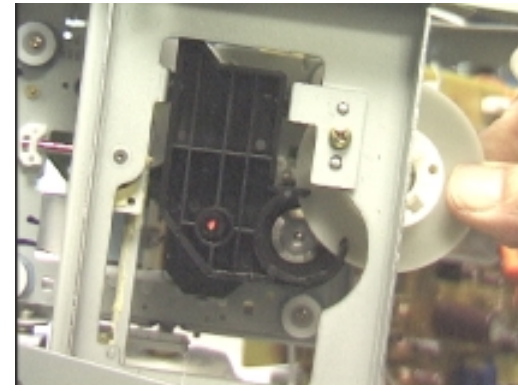

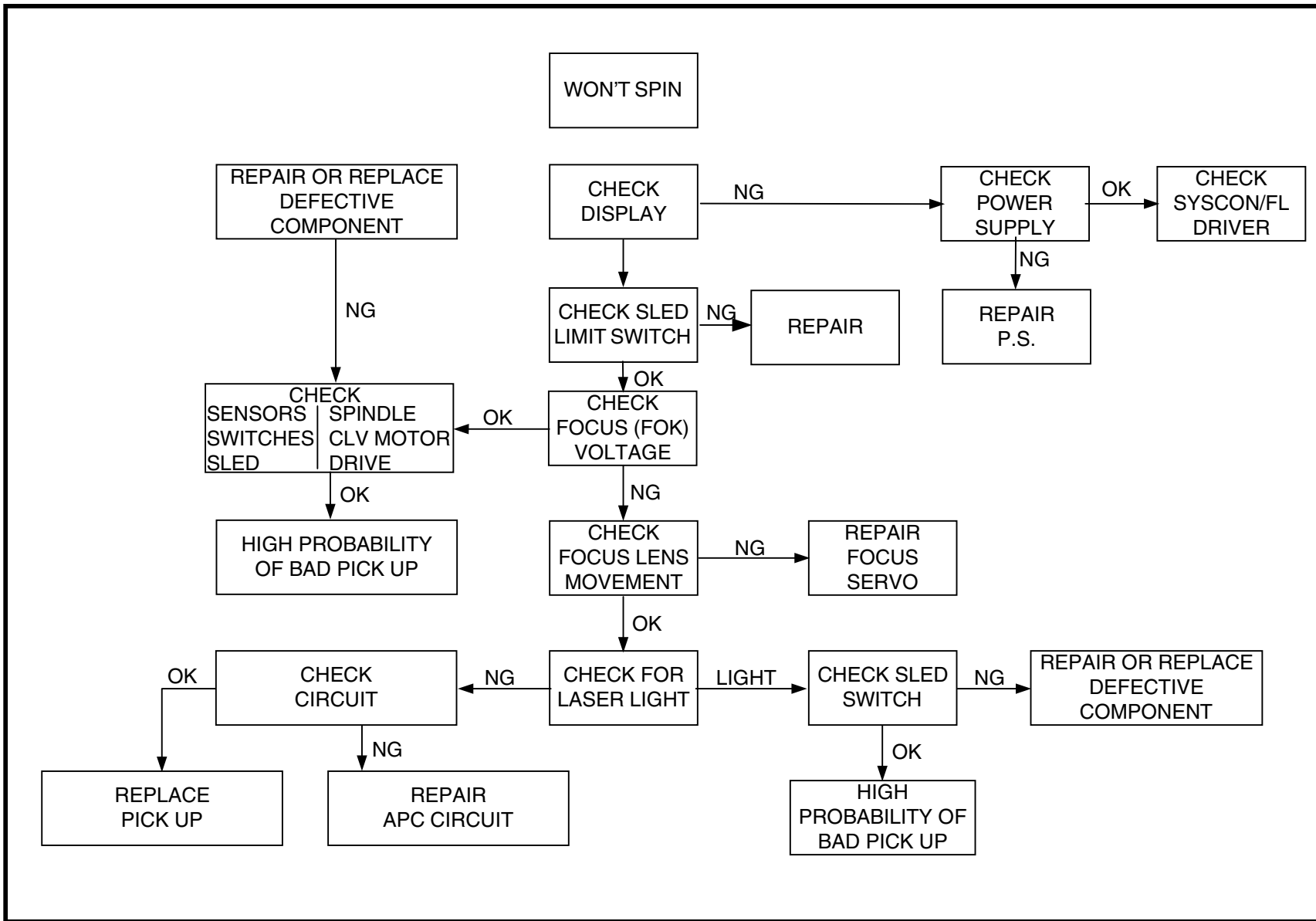

DISC WON'T SPIN FLOW CHART

- Without CDs in the tray table, momentarily place your fingers between the disc tray and the luminous sensor as you turn the power on. The changer will mistakenly sense many discs, attempt to load them and turn on the laser.



- Through the opening in the black magnet holder you can measure the laser light with the laser meter probe. See the picture in step 1. **DO NOT LOOK AT THE LASER LIGHT.** You may see the laser reflection by placing a piece of white paper in the laser path.
- Reinstall the magnet assembly.

Focus

Electronic Focus is a two-part operation. The first part is when Servo Control uses the driver to move the lens away from the disc and then slowly back toward the disc looking for the focus point on the disc's information layer. This first part is called "focus search". The second focus operation occurs when focus has been identified by servo control. This is called "focus servo". The transition from search to servo is marked by a HIGH at the FOK test point when focus is found.

The search operation can be observed. The servo operation can be checked at the FOK test point on the BD board with a scope can check the servo operation. The procedure is as follows:

Focus Search Mode

- Enter the Adjustment Test Mode by unplugging the AC power from the changer.

- On the main board, connect the "ADJ" test point to ground. In the CDP-CX235, ADJ is under the large 1-farad capacitor. Ground is the negative lead of the large 1-farad capacitor.

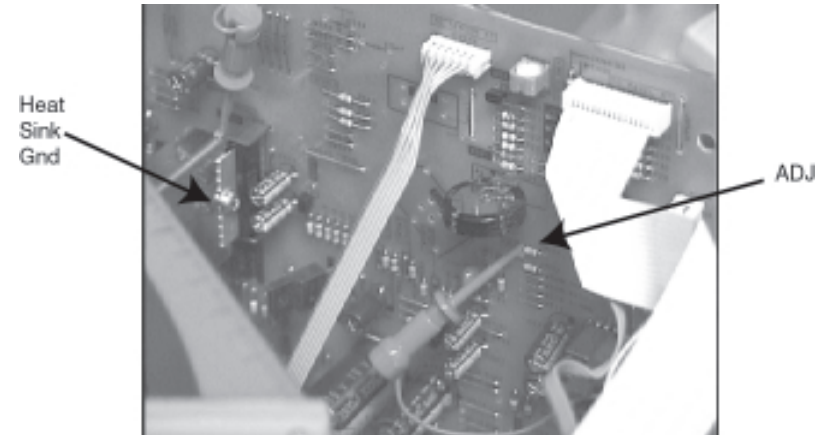

- Plug the CD changer into AC. The unit is in the ADJustment test mode. This mode can be used to manually alter some servo parameters.
- Press the front panel CHECK button while in this test mode. The laser will come ON, the spindle motor will turn, and the optical lens will move in the focus search operation.

Focus Servo Mode

- To make the transition to focus servo, a disc must be inserted so the laser can focus on its information layer. You must exit the test mode to install a disc. Temporarily remove the jumper wire's ground end and unplug power.
- On the BD board locate the RFO and FOK test points and attach your scope probes to them.
- Plug the changer into AC, press the POWER button and then the OPEN/CLOSE DOOR button. Insert a disc (label to the right).
- Press the OPEN/CLOSE DOOR button again to chuck the disc. The door will close and the disc will be loaded into the CD mechanism (chucked).
- Reenter the adjustment test mode by unplugging AC and reconnecting the ADJ test point to ground.

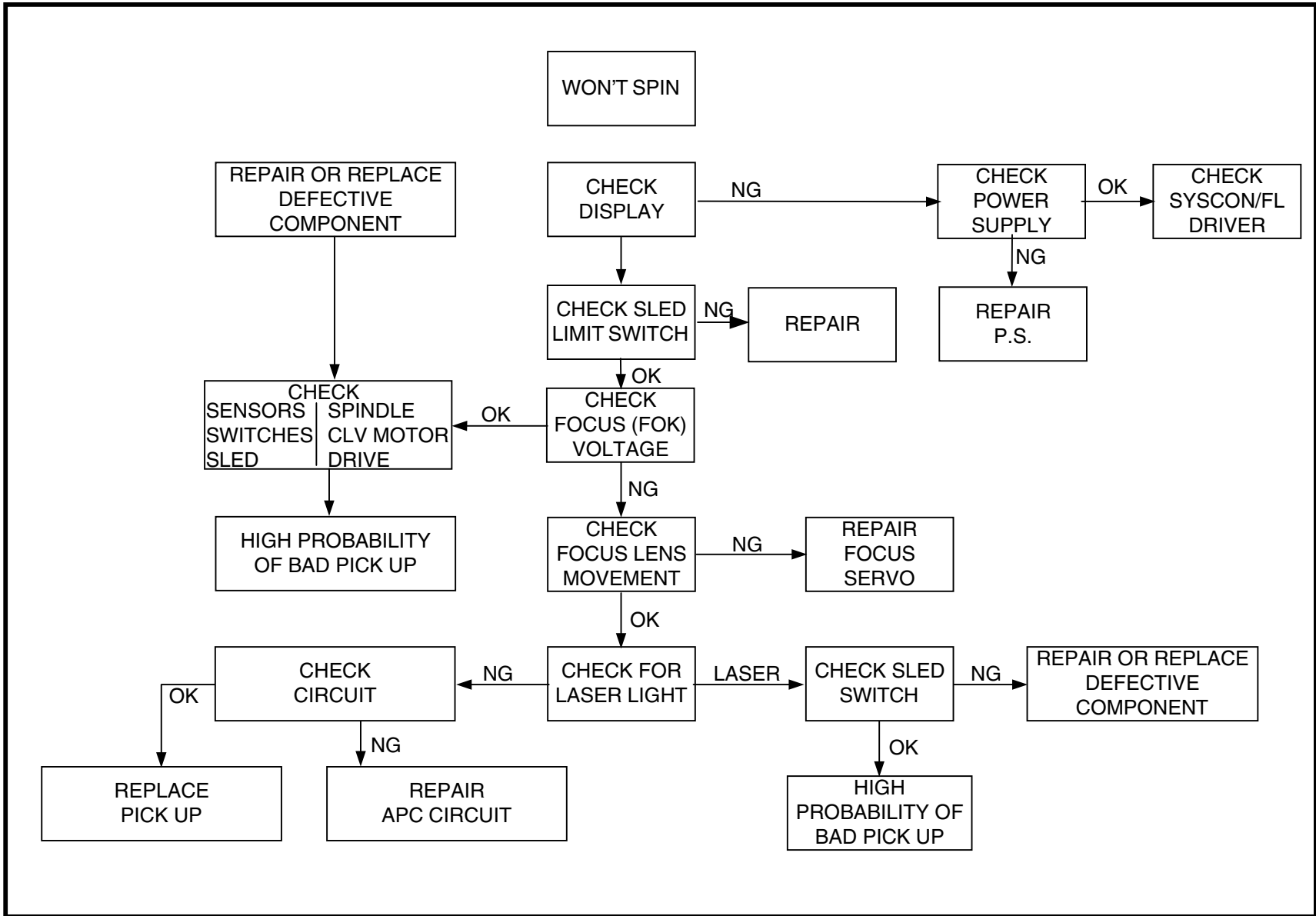

DISC WON'T SPIN FLOW CHART

10. Watch your scope as you apply AC power. If the FOK line goes HIGH, focus has been found. The transition from search to servo is then performed within Servo Control. At this point you know the laser is working and the focus driver part of the IC is good enough to achieve FOK. The following waveform compares the RF output to the FOK signal. This waveform shows RF signal goes HIGH as soon as focus is found. (The spindle motor also starts when FOK goes HIGH producing the RF waveform that follows.)

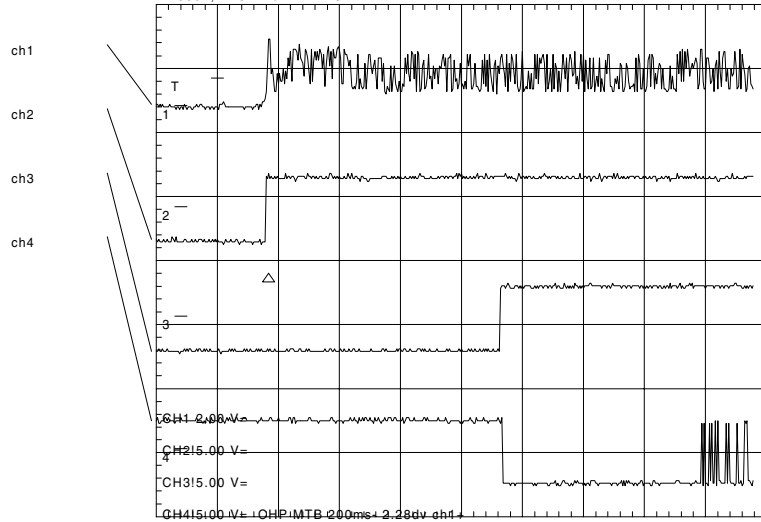

CD Playback Starting		
Channel	Signal Name	Location
1	RFO	IC103/pin 16
2	FOK test point	IC101/pin 24
3	LOCK test point	IC101/pin 25
4	C2PO test point	IC101/pin 19
Time base = 200msec/div		
Scope ground is taken at Vc (IC103/pin 12)		

If FOK does not go HIGH, increase the scope's time base and look at the RFO signal for a rise in voltage as the lens repeats the focus search operation in this test mode. NO RFO means there is no signal from the optical assembly. This could be because there is no laser light or no power (ribbon cable). If there is an RF output during focus search, yet there is no FOK signal, the source of the FOK signal can be checked.

FOK comes from the RFO signal that is derived from the optical detectors A-D. When the RFO reaches a set threshold, FOK goes HIGH proving that there is light returned from the information of the disc (laser and focus OK).

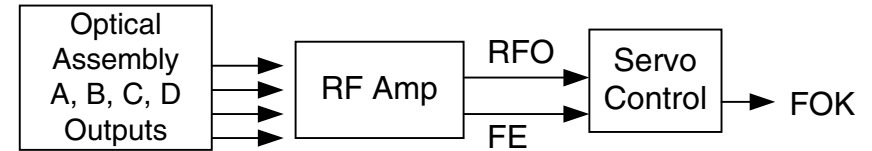

RFO can be compared to FE to see if there is an output before condemning the optical assembly. If there is an output from both, the optical assembly and RF amp IC are OK and the likely suspect is a defective Servo Control IC that makes the FOK signal.

An easy way to see if there is RF under this defective condition is to repeat the Search operation. In the ADJ Test Mode, press the front panel CHECK button. This CHECK button just repeats the search operation, but the servo operation that normally follows will be inhibited so the disc will not play. Place a scope probe at the RFO and FE test points.

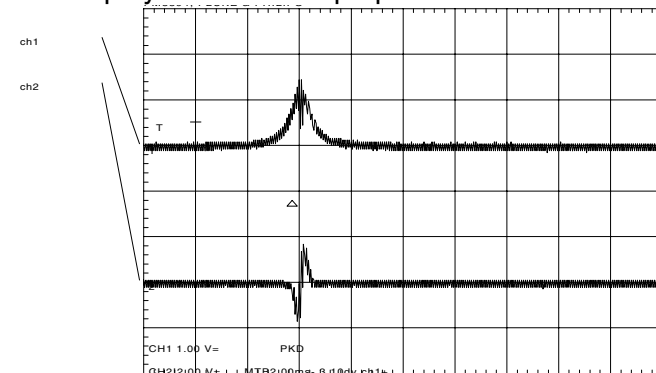

S Curve focus Search (Changer is in ADJust Test Mode)		
Channel	Signal Name	Location
1	RFO test point	IC103/pin 16
2	FE test point	IC103/pin 14
Time base = 2msec/div		
Scope ground is taken at Vc (IC103/pin 12)		

11. Remove the jumper wire between the ADJ test point and ground.

Disc Spins But Doesn't Read The Disc's Table Of Contents (TOC)

If the disc spins, Servo Control knows the optical assembly is at home position and focus was found (so the laser must be good too). Now the quality of the RF signal that is output, and the tracking and spindle servos are in question.

Since the optical assembly and the servo circuitry are linked, it is difficult to determine if one or the other is bad without replacement. The severity of the testing waveform usually distinguishes. If the waveform is extremely bad, the circuitry is often at fault caused by an abrupt failure. A waveform out of spec is often caused by an aging optical assembly.

The RF and tracking servos can be tested, but the spindle motor servo cannot be tested separately.

RF Output

The normal RFO measures about 1.2Vp-p. As the optical assembly ages it drops until a critical level of about 0.9Vp-p, causing skipping, or to about 0.75p-p, causing no playback.

The previous S curve waveform shows that the RF signal appears once focus is achieved. When the disc is beginning to play, the RFO level should rise quickly and produce a waveform. The RF waveform will continue if the tracking and spindle motor servos operate. Comparing the RFO and tracking error signal permits you to see if the optical assembly is weak and check the tracking stage at the same time.

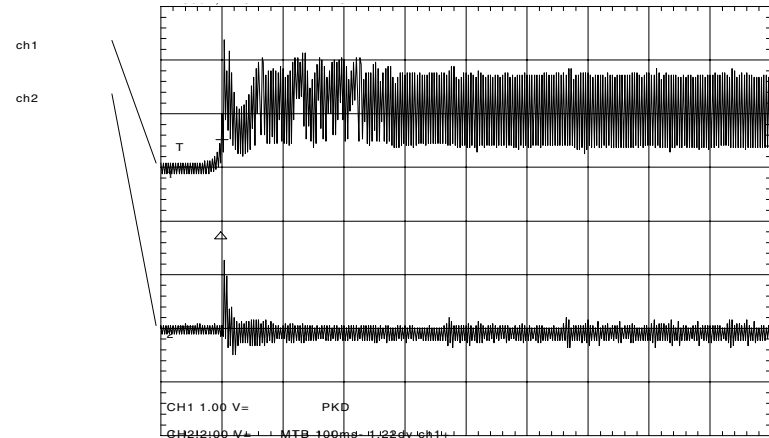

Start up RFO and (TE) Tracking signals		
Channel	Signal Name	Location
1	RFO test point	IC103/pin 16
2	TE test point	IC103/pin 13
Time base = 100msec/div		
Scope ground is taken at Vc (IC103/pin 12)		

Tracking Servo

The tracking servo consists of an electronic closed loop circuit. The loop is completed by Servo Control as soon as focus has been identified using the FE signal.

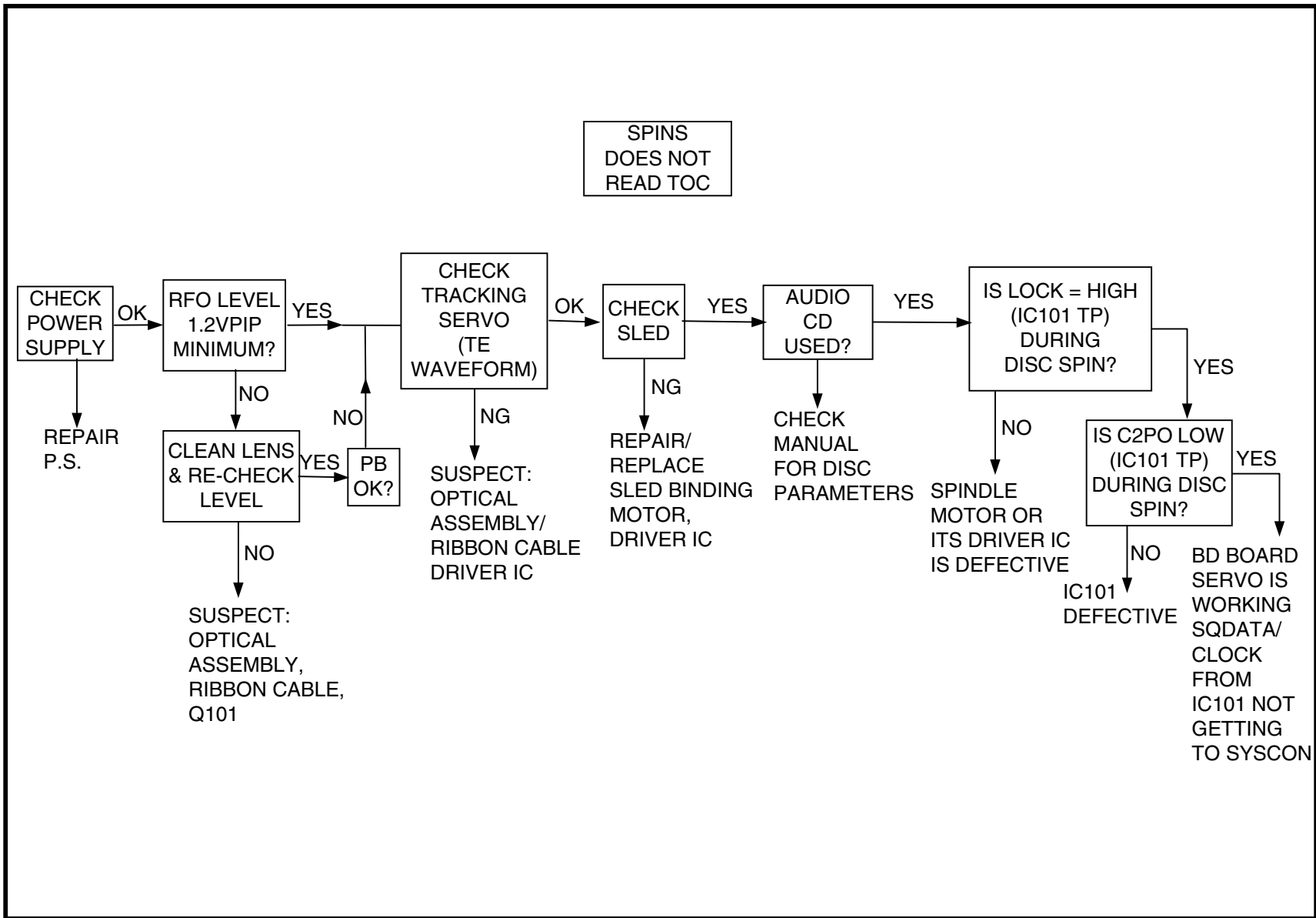

DISC SPINS, BUT DOES NOT READ TOC FLOWCHART

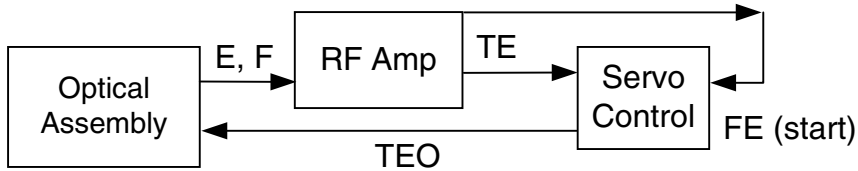

When the tracking loop is broken, the TE waveform changes from what looks like .5Vp-p of noise to a large broken waveform of 1.5Vp-p (Ch 2). The RFO signal shows losses of RF where the laser is crossing tracks.

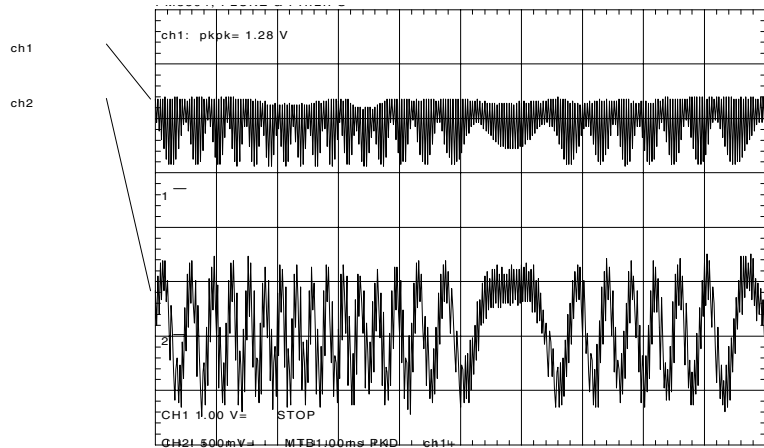

Defective Tracking Servo Waveforms		
Channel	Signal Name	Location
1	RFO test point	IC103/pin 16
2	TE test point	IC101/pin 13
Time base = 100msec/div		
Scope ground is taken at Vc (IC103/pin 12)		

An open tracking loop is not common and is usually caused by foreign objects in the optical assembly, its ribbon cable or a bad driver IC.

Spindle Servo

Even though the spindle motor turns the disc, its servo loop may not be closed. A defective spindle motor servo produces RFO data that alternates between good and bad (even though they both look the same on the scope). Looking at the LOCK test point at the Servo Control tells you if the spindle motor loop is closed, since the focus and tracking servos must

work before the spindle servo can close. For example, if the tracking servo were defective, the spindle servo loop cannot close because the RFO data is unreliable. Therefore the other servos must be checked prior to this check. It also takes a while to process the RFO data to establish a spindle motor lock so the spindle servo is the last servo to engage. This is shown when comparing RFO (Ch 1) to the LOCK test point (Ch 3).

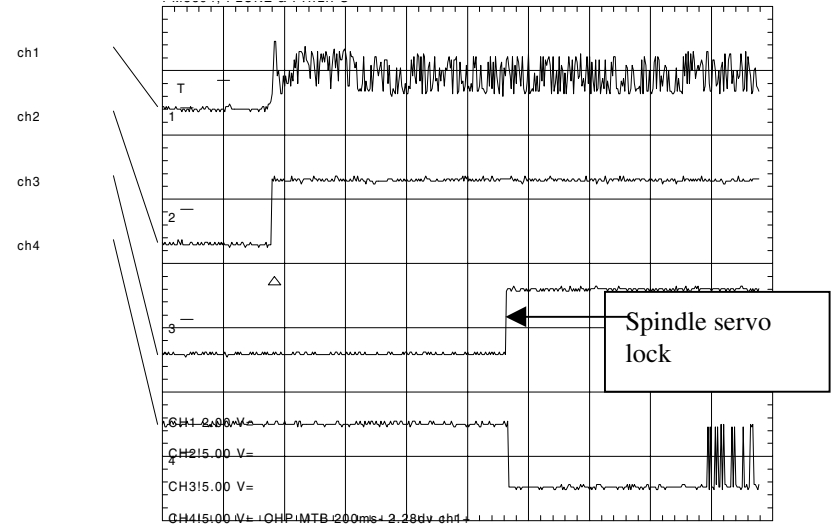

CD Playback Starting		
Channel	Signal Name	Location
1	RFO	IC103/pin 16
2	FOK test point	IC101/pin 24
3	LOCK test point	IC101/pin 25
4	C2PO test point	IC101/pin 19
Time base = 200msec/div		
Scope ground is taken at Vc (IC103/pin 12)		

If all the other servos check OK and the LOCK test point remains LOW (spindle servo defective), the common cause is the motor itself.

No Audio

If the disc is spinning and the LOCK test point is HIGH, the servos are working. Audio should output Servo Control if the RF data is valid, and the IC is OK. Servo Control outputs two clues about the audio produced:

- FL display information (tracks, time elapse)
- L & R Audio Output

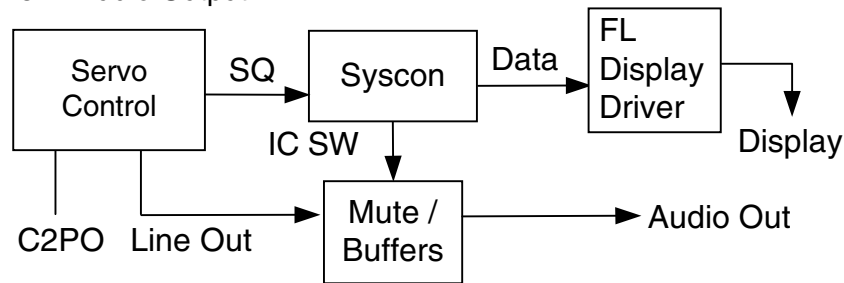

The SQ information updates the display with running time information. The analog audio output goes to buffers and a mute stage before arriving at the rear panel output jacks.

There is also a line output mute inside Servo Control. If the degree of errors in recovering the audio data is high, there is no SQ or line output. Audio recovery can be monitored at the C2PO test point. This point is LOW when digital to audio processing is correct. If the servos are working (LOCK = HIGH), there is no reason C2PO will be HIGH (defective) unless the disc is scratched or the Servo IC is defective. In the CD Starting Waveform, the + pulses at the right of the C2PO waveform designate disc scratches, causing uncorrectable errors.

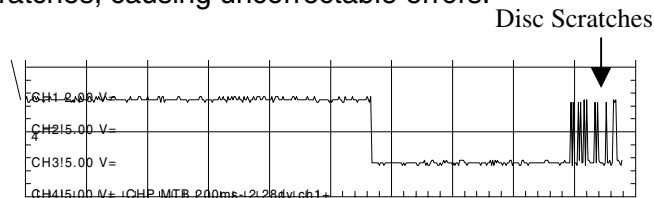

CD Playback Starting C2PO tp	
Signal Name	Location
C2PO test point	IC101/pin 19
Time base = 200msec/div	
Scope ground is taken at Vc (IC103/pin 12)	

Optical Assembly Tests

There are three basic checks for the optical assembly.

S Curve Check

In this procedure you will check the A-D detectors to see if they are balanced with sufficient output level to produce RFO for play.

1. Load a YEDS-18 test disc into the CD changer so it is chucked.
2. Unplug the CD Changer from AC.
3. Connect the DC coupled scope to FE1 on the BD board.

[BD BOARD] - Side B -

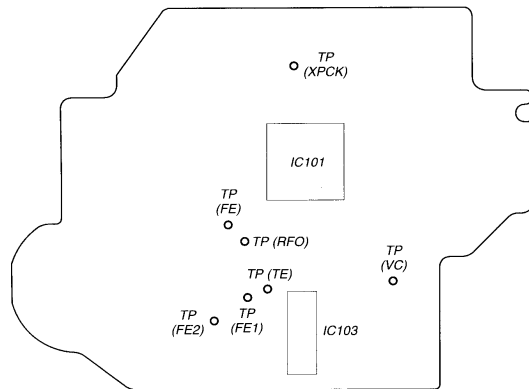

4. Jump ADJ on the Main board to ground.

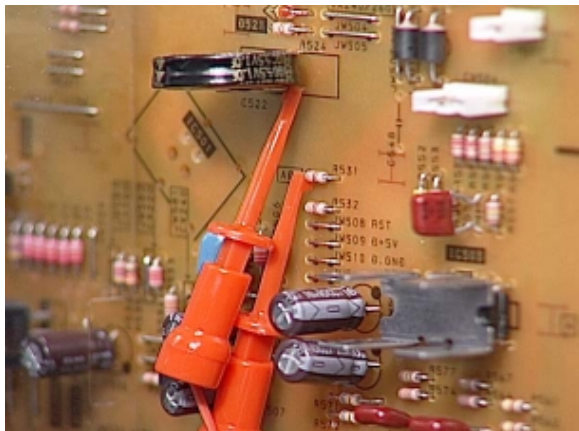

5. Plug the CD Changer into AC to enter the test mode.
6. Press the Front panel CHECK button to activate and repeat focus search. An S curve waveform should appear.

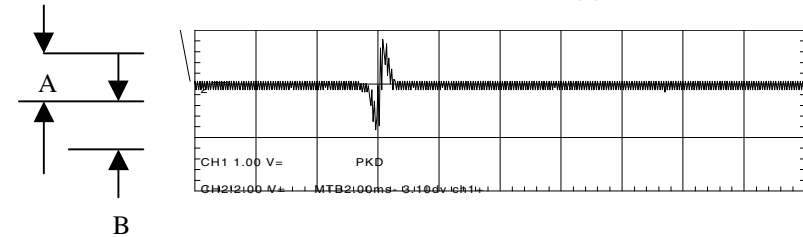

The S curve should be between 2 to 4Vp-p and must be symmetrical above and below the base line (A=B).

7. Unplug the AC to escape from the ADJ test mode.

E-F Balance Check

In this procedure you will check the E & F tracking detectors. Defective detectors will cause skipping.

8. Plug the CD Changer into AC and press the Power On button.
9. Touch your DC coupled scope to the Vc test point on the BD board and mark this reference position on the scope with masking tape. Vc will be about 2.5Vdc.
10. With the disc still chucked and the ADJ test point grounded, move the scope probe to the TE test point on the BD board.
11. Press the  to select track 5 and press PLAY.
12. Press the front panel GROUP 3 button to disable the tracking servo. The small 0.5Vp-p tracking error signal will change to a large 1.4Vp-p traverse wave.

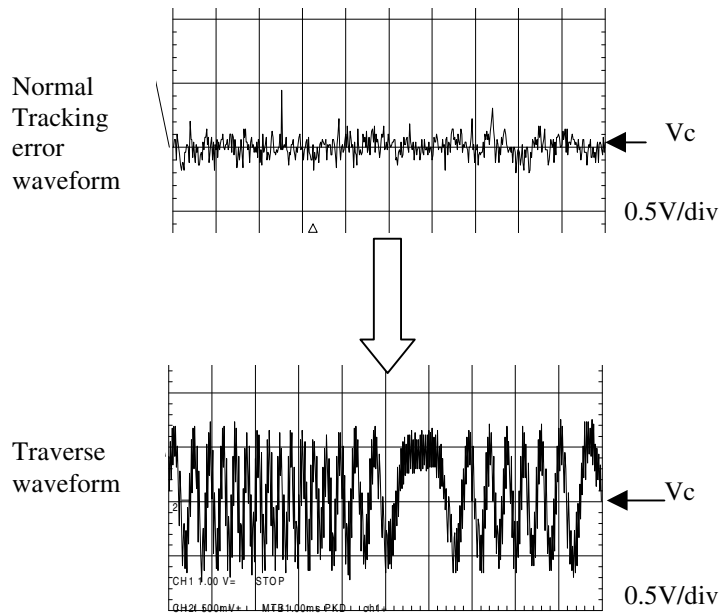

RFO Level Check

The RFO level must be at least 1Vp-p.

Move the scope probe to the RFO test point on the same BD board.

While the disc is playing, the output level should be at least 1Vp-p (spec is 1.2Vp-p).

13. The Traverse waveform should be no smaller than 0.7Vp-p.

14. Measure the DC voltage from the Vc reference to the center of the waveform (offset voltage). As the optical assembly ages, these two will not be the same.

In this example Vc is the same point as the center of the waveform so step 14 = 0Vdc offset.

15. Divide the offset voltage measured in step 14 by the waveform's Vp-p. and multiply by 100. The result must be less than 22%

Offset DC voltage / Traverse Wave Vp-p X 100 = imbalance %

16. In our example, the waveform is 1.2Vp-p. Dividing 0/1.2V = 0% which is less than 22%

17. Press the GROUP 8 button to restore the tracking servo and examine the normal tracking waveform.

18. Measure the TE waveform DC offset voltage. It must be almost the same as the offset measured in step 13. If not, there is metal fatigue in the lens supports of the optical assembly (defective).

APPENDIX

Control A Communications for Additional Features

Control A is the name given to the Sony bi-directional communications format used in Sony home audio devices. The purpose of the communication is to automatically perform system functions and provide extra features for the user.

Additional Features

Additional features are gained when a CD Changer is connected to other Control A audio devices such as CD Players, Mini Disc Recorders, Receivers, etc. These features are related to the devices connected to the CD Changer:

Receiver - CD Changer

- Automatic Function Selection – When the CD Play button is pressed, the receiver will switch to the CD input. Both audio devices must already be powered ON.

Mini-Disc or Tape Recorder - CD Changer

- Automatic Function Selection – When the recorder’s Play button is pressed, the receiver will switch to the Aux (Mini-Disc) or Tape input. Both audio devices must already be powered ON.
- Synchronized Recording – The selected CD song track will begin playing just after recording. This is achieved by presetting the recorder and CD Changer to the Record-Pause and Play-Pause mode respectively. When the Recorder’s Pause is released (press pause button), the CD player will release pause shortly afterwards.

Another CD Changer - CD Changer

- Program Play from both CD Changers – Play one song or disc after another from either CD Changer (3 Changers is the maximum at this time). The procedure is: On one changer, press the Program button until the program # appears (program 1, 2, 3, etc) on the display. If the first track you want to program is on the first CD Changer, skip this next step. If the first track is on the second CD Changer, press the

“Player Select” button until “Second Player” appears. Turn the Jog dial until the disc # you want appears on the display. Press Enter to Program the whole disc or select a track using the >> (fwd) button, and then press Enter.

- Cross (X) Fade Playback (some CD Changer models) – This feature enables you to fade in (start) the next song on the second changer while the current song is fading (out) to an end, thereby mixing the two songs at this time. This feature is activated by first pressing the Continue or Shuffle Play button to select the songs or discs desired:

Continue and Shuffle Play X Fade Options		
Button	Option	Function
Continue	All Discs	Tracks from each changer are alternately played, starting from the first track in the first disc of the two changers.
	1 Disc	Tracks from each changer are alternately played, from a selected disc in each changer.
Shuffle	All Discs	Tracks from each changer are alternately played randomly from all discs in each changer.
	1 Disc	Tracks from each changer are alternately played, from a selected disc in each changer.

Next the X Fade button is pressed and finally the Play button is pressed to start the program.

- Display Custom Files from both CD Changers on the TV (1 Changer must be a model CDP-CX270 or CDP-CX90ES) – The procedure is simply connect the video output from the CD Changer to the video input of the TV. Use the CD’s remote commander to navigate. Press “Player Select” to vie the second changer contents on the TV screen.
- Hide the CD Changers from view – When the audio devices are connected by Control A cables, any device that contains an IR remote receiver will send the received IR “SIRCS” signal to all the devices on

the Control A bus. The SIRCS signal is product specific so only the device the command is designated for will respond, even though all devices receive the command.

- No Delay of Playback between CD Changers – The next disc in the programmed (or shuffle) play order will load and pause 30 seconds prior to the current track ends so there is no delay in playback.

Generations of Control A

There are three Control A software formats. The formats are backwards compatible.

Control A – Used on early 50 and 100 disc CD Changers enabling the auto function selection and Syncro Recording features. The first generation used a 3.5mm stereo miniplug instead of the current mono plug used in future generations. Connecting old and new units using a stereo to mono cable can make them hardware compatible.

Control A1 – Used on 200 disc CD Changers, permitting more system features as listed, enabling automatic operations associated with integrated systems. This second generation format began the use of a 3.5mm mono miniplug for bi-directional communications.

Control A1 II – Began on the 300-400 disc CD Changers in the year 2000. The version II software additions to the changer's microprocessor permits audio – video system functions that are not at full potential as of this writing.

Control A Hardware Connections

Connecting the audio devices for communications requires a coax cable (2 meters max length) with a 3.5mm mono miniplug at each end. Each audio device is linked to another using these cables forming a series. The cable plugs into either one of the two Control A jacks at the rear of the audio device (the receiver only has 1 jack so it must be at the end of the path).

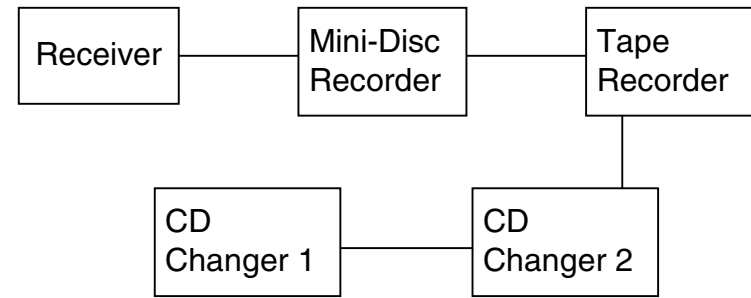

There is a three-position command mode slide switch next to the Control A jacks of the newer CD Changers. The older changers are considered in position one (1). The command switch selects the CD player number. This is useful if you want to control the CD Changers independently or as a group.

If you want to control the changers independently you would assign each changer a different position number. Then if you wanted to select a disc from the second changer by remote, side the remote's CD switch to #3 to access changer #3.

If you want to group two changers for combined features so they operate together, place two of the changers into position #2. Then you can use some of the features that share changer operation like Displaying Custom Files on the TV screen, Program Play, or Cross (X) Fade Playback.

Defective Discs

Various problems can be found in CDs that cause skipping or clicking sounds (momentary muting) when played. Close examination of the RFO waveform can identify a defective disc.

Normal RFO

At start up, laser light from the optical assembly is reflected from the information layer of the disc to the optical assembly detectors. This returned laser light causes the RFO voltage to go initially HIGH.

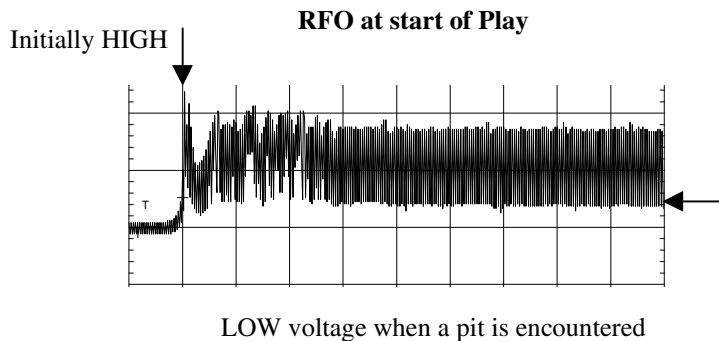

The information layer consists of a reflective mirror area and data pits of variable length. These pits are of precise width and depth so light cancellation can occur. As the disc begins to spin, the laser falls on a data pit and its light is reduced (canceled) so less light is returned to the detectors. How long the light reduction takes place is dependent upon how long the pit is. Light reduction yields a LOW RFO voltage.

In summary, it is the transitions from the mirror area to the pit area that create the HIGH to LOW transitions of the RFO voltage. Therefore the Vp-p transitions of the RFO are dependent upon the reflection quality of the mirror area and the depth of light cancellation in the pit area.

Disc Defects

Disc defects affect the RF signal in several different ways:

iii

Center Hole Misalignment

This causes a wobble in the disc and a corresponding bounce in the RF waveform. If the off-center hole is real bad, the disc will not play.

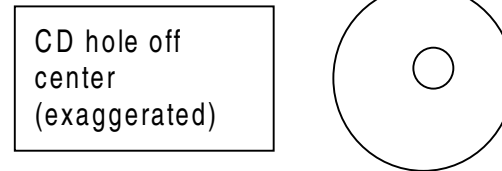

Bubble in the Plastic CD

The bubble diffracts the laser light so less light is returned. This causes a LOW in the RFO waveform.

Information layer is Peeling off, or too Thin.

This causes a reduction of RFO level similar to a low output laser or dirty lens. Try a known good disc or the YEDS-18 test disc (P/N = 3-702-101-01). If the Vp-p RFO is still low, clean the lens.

Missing Information Layer

When a chunk of information is missing, there is a loss of light returned to the detectors. The RF level drops low at this time and there is a click in the audio when this disc area appears because the audio cannot be compensated for, so muting is the last alternative.

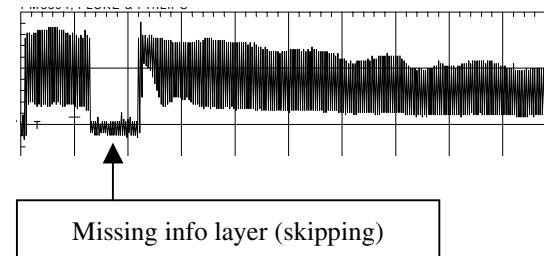

Black spot

If the stamped disc remains too long on the die, the plastic may be burnt black. During PB, this black spot causes a momentary loss of RF, which momentarily mutes the music (causing clicking sounds).

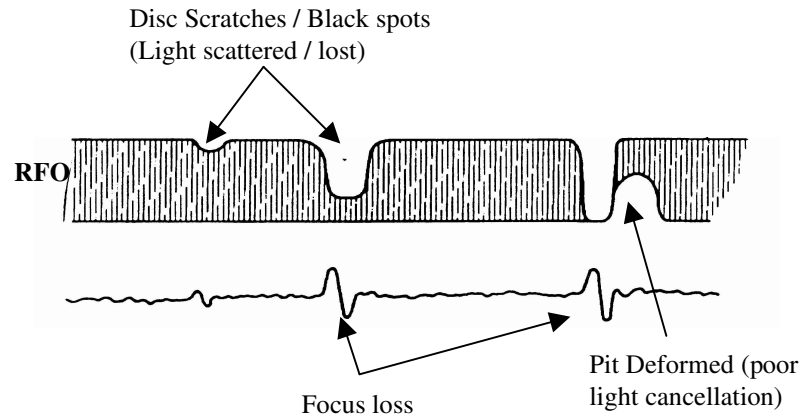

Scratched Disc

A scratched disc will scatter some laser light as the laser enters the disc. Since this light will be lost, the RFO voltage will be reduced. If the scratch is small, the lost data is electrically error corrected or predicted in the electronics. If the scratch is larger, muting will occur. If still larger, momentary loss of focus and skipping will occur.

Pit Deformed

As the CD manufacturing (stamping) die wears, the shape of the pits on the disc may not be molded to the correct shape or depth. This causes the RF voltage to not have enough depth (reduced V_{p-p}) when played back.

Troubleshooting Using the RFO Waveform

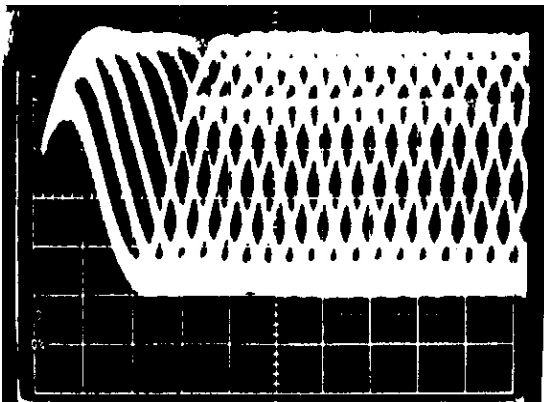

Normal RFO ("Eye") pattern
1.2Vp-p
Time base = 0.5usec/div.

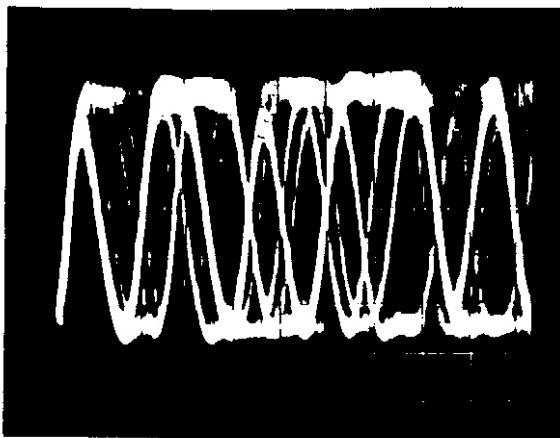

Normal RFO in-between songs
1.2Vp-p
Time base = 0.5usec/div.

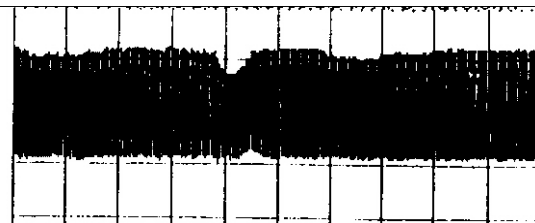

RFO during PB of a scratched disc. Notches in the envelope appear on top and sometimes bottom.
1.2Vp-p
Time base = 0.5msec/div.

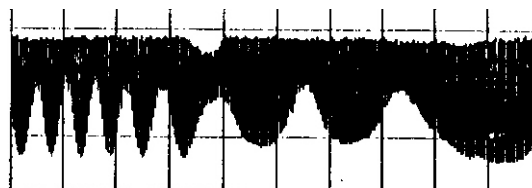

RFO when the tracking servo is open (defective).
1.3Vp-p
1msec/div.

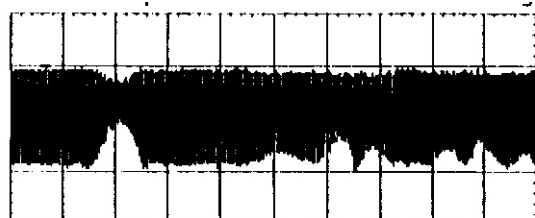

RFO when the spindle motor is bad. The motor's worn bushing causes vibration that upsets the tracking servo. This causes the scalloping along the bottom of the waveform

**Abbreviations
Used In
Compact
Disc
Player**

####FS	Clock - or x of S ample Frequency	A division or multiple of a clock or sample frequency. (Example: 8FS = 44.1 kHz x 8 = 352.8 kHz)
APC	A utomatic P ower Control	Laser power control circuit
ASY	A Symmetry Control Signal	The EFM signal low pass filtered and fed back to the EFM comparator for squaring the RF signal into the EFM signal.
ATSC	A utomatic Tracking Sensitivity Control	Detects input for automatic tracking servo gain control.
ATTM	A TTenuate	Attenuates the audio output by 12 dB.
BCK	B it Clock	The clock used to read the serial data.
BW	B and W idth	Time constant for PLL low pass filter.
C16M	C lock 16 MHz	Divided crystal clock.
C1F1	C orrector 1 Flag 1	Part of a binary number indication the degree of error correction.
C1F2	C orrector 1 Flag 2	Part of a binary number indication the degree of error correction.
C21O	C lock 2.1 MHz Output	Serial audio data output bit clock.
C2F1	C orrector 2 Flag 1	Part of a binary number indication the degree of error correction.
C2F2	C orrector 2 Flag 2	Part of a binary number indication the degree of error correction.
C2FL	C orrector 2 Flag out	Error corrector output indicating that data output contains errors
C2PO	C orrector 2 Pointer Out	too large to correct and that the sample has been interpolated.
C4LR	C lock 4x Left Right Clock	176.4 kHz
C4M	C lock 4 MHz	Divided crystal often uses as microprocessor clock.
C864	C lock 8.64 MHz	PLL's VCO output at 8.64 MHz
CLTV	C ontrol Loop Timing Voltage	Feedback to control the PLL gain and timing.
CLV	C onstant Linear Velocity	Maximum data density is afforded the CD format by maintaining a constant data spacing and rate. (Changing vs. constant disc spindle RPM).
CNIN	C ount I n	Signal used to count track jumps. (Example: during AMS search).
C. OUT	C ount O UT	Track jump counting signal.
CRCQ	C yclic Redundant Check Q	Indicates when errors have been found in the Q data.
DAO#	D Ata Out	Either 16-bit serial or one of 16 parallel bits indicated by including it's number.
DFCT	D EFACT	The signal detected from and indicating a defect in the RF signal. Holds last focus & tracking errors.
DIRC	D IRect Control	Used by system control to cause a one-track jump.
DOTX	D igital O ut for e Xternal	Serial data for direct (external) digital output from player.
EFM	E ight to Fourteen Modulation	The data modulation scheme used to increase data density. Also use to identify the RF data signal after it has been squared.
EMPH	E MPhasis	The signal indicating the audio was pre-emphasized.
ESP	E lectronic Shock Protection	Playback at double speed using pause and a buffer RAM to provide continuous playback data during mechanical disturbances.
EXCK	E Xternal Clock	The SBSO contains one of the P thru W data words relative to this external clock input.
FE	Focus Error	The difference signal of (A+C) - (B+D) main spot detectors.
FFDR	F ocus F orward D Rive	Focus coil drive error signal.
FFON	F ocus F orward O N	
FRDR	F ocus R everse D Rive	
FRON	F ocus R everse O N	
FGD	F ocus G ain D own	Filter circuit to reduce focus gain with internal switching.
FILI FILO	F ILter In or O ut	Input/output for a low pass filter.
FLB	F ocus L ow B andwidth	Used to set low frequency response of focus servo.
FLGL	F La G Left or Right	Identifies data for left & right channel audio.

FSET	F requency S ET	Sets the peak frequency response for focus, tracking, & CLV.
FSW	F ilter S Witch	Activates the CLV servo filter circuit during run-up.
GFS	G uarded F rame S ync	Active when frame sync data is being read from the disc.
?! ?O?	I n or O ut	Used with other letters to indicate signal direction.
LD	L aser D iode	APC circuit output to control laser power.
LDON	L aser D iode O N	On/Off control for the APC circuit to control laser power.
LOCK	L OCK	Norm = H. L = GFS is low > 8 frames. Turns sled off and focus & tracking gains down.
LRCK	L eft R ight C lock	44.1 kHz clock identifying left and right channel data.
MIRROR	M IRROR	The signal detected from the RF and indicating that there are no pits are present such as when between tracks.
MD1	M oDe 1	Selects frequency of clock input. L = 16.9344mhz, H = 8.4672MHz.
MD2	M oDe 2	Selects direct digital output mode from DOTX. L = On (data output), H = Off (WFCK is output instead).
MD3	M oDe 3	Selects internal digital filter mode. L = On, H = Off.
MDP	M otor D rive P hase	The phase (fine) CLV servo error. (Compares data rate to crystal.)
MDS	M otor D rive S peed	The speed (course) CLV servo error. (Compares VCO to crystal.)
MON	M otor O N	On/Off control for the CLV spindle servo
MUTG	M UTInG	Mutes the audio output.
PCI PCO	P hase C omparator I n or O ut	The input/output of the PLL phase detector/comparator.
PD	P hoto D iode	The output of any of the detectors in the pick-up assembly.
PLCK	P hase L ocked C lock	4.32 MHz clock divided from the phase locked VCO. Used as the bit clock to process and write data before RAM.
P/N	P -sub/ N -sub	Switches LD output for P or N substrate lasers.
PSSL	P arallel/ S erial output S eLect	Selects the audio data output format. L = Serial, H = Parallel.
RAOV	R AM O verflow	Indicates that an error has occurred that is too large for the error correction RAM to hold.
RF	R adio F requency	The amplified main output signal from the pick-up containing the data from the disc. Also called the Eye or Fishnet Pattern.
RFAC	R adio F requency A lternating C urrent	The RF output signal used for detecting audio data (EFM), DEFECT, and MIRROR signals.
RFOK	R ead F rame C lock	7.35 kHz clock divided from crystal reference. Used to read and process data after RAM.
RFDC	R adio F requency D irect C urrent	The RF output signal used for detecting the FOK signal.
SBSO	S ub S erial O ut	see SQSO
SCOR	S ub C ode O R gate output	Indicates the start of the sub code (Q data) words. (75Hz)
SE	S led E rror	Error signal input to the sled servo.
SENS	S ENSE	The multi-purpose signal line used by the servo and digital signal processor for feedback to the microprocessor. Depending on the operating mode, it contains one of the following: S STOP, FZC, Count, Complete, etc.
SFDR	S led F orward D rive	Sled motor drive error signal.
SFON	S led F orward O N	
SRDR	S led R everse D rive	
SRON	S led R everse O N	

SQEX	Sub Q External	Selects synchronizing of the sub code Q data output. L = synched to WFCK, H = synched to EXCK
SQSO	Sub code Q data Serial Out	The data extracted from the disc containing information for system control. (TOC, etc.).
SUBQ	SUB code Q data serial out	
SRCH	Search	Time constant connection for focus search ramp.
SSTOP	Sled STOP	Indicates that the sled has stopped.
TE	Tracking Error	The difference signal from the E and F side spot detectors.
TFDR	Tracking Forward Drive	Tracking coil drive error signal.
TFON	Tracking Forward ON	
TRDR	Tracking Reverse Drive	
TRON	Tracking Reverse ON	
TGU_2	Tracking Gain Up or 2	Gain control components for tracking servo.
TOC	Table Of Contents	Data from the disc, found at the beginning, containing all information about the disc for system control and display.
TZC	Tracking Zero Cross	Detects when tracking error crosses through zero (during jumps).
UGFS	UnGuarded Frame Sync	Synchronized clock derived signals are used when frame sync is momentarily lost.
VC	Voltage Center	Reference voltage equal to 1/2 the supply across the IC.
VR	Voltage Reference	
VCOF	Voltage Controlled Oscillator Frequency	Sets the free run frequency of the PLL s VCO.
WFCK	Write Frame Clock	7.35 kHz clock divided from phase locked VCO . Used to write and process data before RAM.

SONY

SEL Service Company
A Division of Sony Electronics Inc.
1 Sony Drive
Park Ridge, New Jersey 07656

A1220700

Printed in U.S.A.